

INDEX

Spec Sheet

FRAMES – GENERAL INFORMATIONF

F-SERIES

F16 and F14-Series Flush FramesF1
Heavy/Extra-Heavy Duty Commercial and Institutional

F18-Series Flush FramesF2
Light Duty Commercial

F12-Series Flush FramesF3
Maximum Duty Commercial and Institutional

FN-SERIES

FN16 and FN14-Series Flush FramesFN1
Heavy/Extra-Heavy Duty Commercial and Institutional

FN18-Series Flush FramesFN2
Light Duty Commercial

DW-SERIES

DW16-Series Drywall FramesDW1
Heavy Duty Commercial and Institutional

DW18-Series Drywall FramesDW2
Light Duty Commercial

K-SERIES

K16 Drywall FramesK1
Heavy Duty Commercial and Institutional

K18-Series Drywall FramesK2
Light Duty Commercial

MU-SERIES

MU16-Series Multi-Use FramesMU1
Heavy Duty Commercial and Institutional

MU18-Series Flush FramesMU2
Light Duty Commercial

FE-SERIES

FE16 and FE14-Series Double Egress FramesFE1
Heavy/Extra-Heavy Duty Commercial and Institutional

DE16 and DE14-Series Double Egress FramesFE2
Clear Width Corridor Application
Heavy/Extra-Heavy Duty Commercial and Institutional

STEELCRAFT®

FRAMES – GENERAL INFORMATION

GENERAL FRAME INFORMATION

Steelcraft framing systems are designed to fit virtually all construction requirements for commercial building applications. Their construction, durability and flexibility have been proven throughout the world in both operation and physical testing of all types.

A brief summary of the framing systems covered in this manual follows:

• Flush Frames (F and FN-Series):

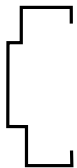

These frames are designed for installation as part of the wall framing sequence, and installed in interior and exterior applications. When installed, this frame series will either wrap or butt up against the wall construction. Anchoring will be either into the masonry wall, or to the stud systems.

• Drywall Frames (DW and K-Series):

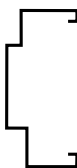

These frames are designed for interior application and for installation in rough openings after the wall is up and finished. They can be installed in minutes and can be relocated without damage to the frame. When installed, this frame series will wrap the wall construction. Anchorage will be to the stud systems.

• Multi-Use Frames (MU-Series):



Like the F-Series frames, these frames are designed for installation as part of the wall framing sequence, however, they are similar to the DW-Series Frames but are installed in either interior or exterior applications. When installed, this frame series will either wrap or butt up against the wall construction. Anchoring will be either into the masonry wall or to the stud systems.

SIZES AND PERFORMANCE:

All framing systems are manufactured and supplied to meet the dimensional standards and performance levels as published in ANSI A250.8-1998 (commonly referred to as SDI-100).

Special size products are available to meet the unique construction, performance and aesthetic requirements of the architectural community. Contact Steelcraft for those requirements.

USAGE AND APPLICATION:

To help simplify the use, selection and specification of Steelcraft framing systems, the following guidelines for base material selection can be used:

Material gage - the following base material thicknesses are available:



18 gage (1 mm) - for Light Commercial applications with minimal use and abuse. It is recommended that the door applications be limited to either L20-Series or hollow core wood doors.



16 gage (1.3 mm) - for Heavy Duty Commercial and Institutional applications with high use.



14 gage (1.7 mm) - for Extra-Heavy Duty Commercial and Institutional applications with potential of very high use.



12 gage (2.5 mm) - for Maximum Duty Commercial and Institutional applications with extremely high use.

Material selection - in addition to the thickness of base material, the following base material types of metal are available:

- Commercial quality carbon steel conforming to ASTM specifications A568 and A569 is commonly used on interior openings.
- Galvanized Steel is recommended for use on exterior openings or for interior locations where high humidity is present.
- Hot Rolled Steel (commonly referred to as HRS) is used on F12 series frames.

STEEL FRAMES:

Three sided steel frames are furnished in three pieces (two jambs and a head) which are anchored to the wall systems. The most common 3-sided frames are for single doors, and their frame components are:

1. **Hinge jamb** – Frame member on which the door is hinged.
 - For double doors (pairs), there are 2 hinge jambs and no strike jamb
2. **Strike jamb** – Frame member into which the door latches.
 - For double doors (pairs), there is no strike jamb, but there are 2 hinge jambs
 - For push/pull there is no strike prep
3. **Head** – The member which connects the jambs.

HOW THEY ARE SUPPLIED:

The connecting corners of the three-(3) piece frame include precision factory die miters and interlocking tabs and corner clips. The corner miters are specially designed to insure a tight closed corner connection when installed properly. There are two methods of furnishing 3-sided frames to the job site:

- **Knock Down (KD)** – Frames are supplied in 3 pieces for assembly prior to installation at the job site, and by the installing contractor. This is an economical method of supplying the frames, and at the job site there is less room consumed in staging the products, easier job site movement of material, and usually less damage to the frame prior to installation.
- **Set-up and Welded (SUA)** – Prior to arriving at the job site, the 3-sided frame (with factory miters) is assembled (at the distributor's fabrication location, or by Steelcraft). The miters are welded (in accordance with ANSI A250.8-1998), finished and supplied to the job site ready for installation. SUA frames are shipped to the jobsite with temporary shipping bars attached. The temporary shipping bars must be removed prior to installation. Due to the installation process, the Drywall Series of Frames (DW and K) are not supplied as welded (SUA).

Details are subject to change without prior notice.

© 2000 Steelcraft Co.
Printed in USA

PROFILE TERMINOLOGY:

The frame profile has specific terminology related to each surface. Their jamb depth describes the frame size required. It is critical that the throat opening be compatible with the wall to which it will be attached.

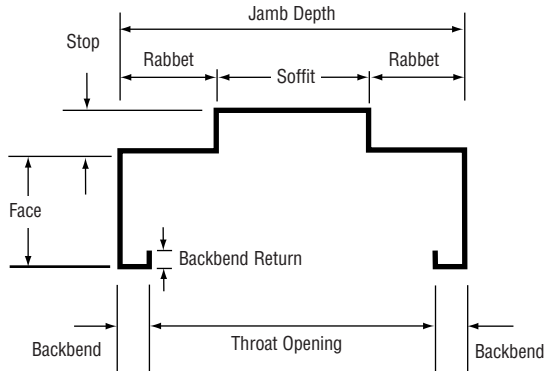

PROFILE VARIATIONS:

Steel frames are supplied standard as double rabbet. To accommodate various application needs, the frame profile (in any frame series) can change. Some of the typical variations are as follows:

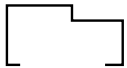

Single Rabbet – Jamb depths below 4³/₄" (121mm) are single rabbet due to the dimensional limitations of the profile. Some specifications will require single rabbet profiles on frames over 4³/₄" (121mm) in jamb depth.

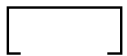

Cased Open – Used for double acting doors (swinging in both directions), sliding doors, bi-fold doors or doors used to close off an opening in a wall when a door is not required.

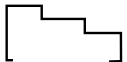

Double Egress – This is a frame specifically designed for cross corridor applications where traffic control is required. This frame is not available in the Drywall series (DW and K).

JOBSITE STORAGE:

Frames shall be stored under cover on 4" (100mm) wood sills, on the floor, in a manner to avoid contact with moisture, and to prevent rust and damage. Do not use non-vented plastic or canvas shelters which create a humidity chamber and thus promote rusting. Assembled frames shall be stored in a vertical position, five (5) units maximum in a stack. Provide a 1/4" (6mm) space between the frames to promote air circulation.

INSTALLATION:

Refer to the Spec Sheets for the appropriate frame series.

Installation of all Steelcraft framing systems shall conform to the published Steelcraft installation instructions, SDI 105 *Recommended Installation Instructions for Steel Frames*, and ANSI/DHI A115-IG *Installation Guide for Doors and Hardware*. All fire rated frames must be installed in accordance with NFPA Pamphlet 80 and/or the local *Authority Having Jurisdiction*.

Typical Frame

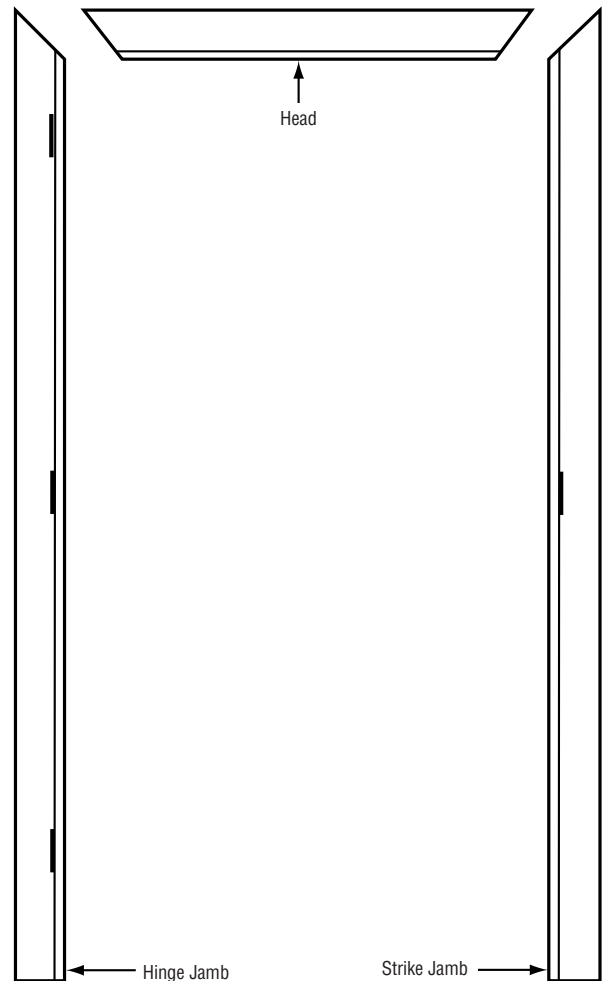

NOMENCLATURE:

Steelcraft frames are described and marked with easy to follow product identification nomenclature. The markings identify the frames by frame series, gage, jamb depth (to accommodate wall thickness), width/height, frame depth component and hand. The following example is a brief guide to the nomenclature used by Steelcraft: **F 16 UL 4 5 3/4 30 70 R ASA**

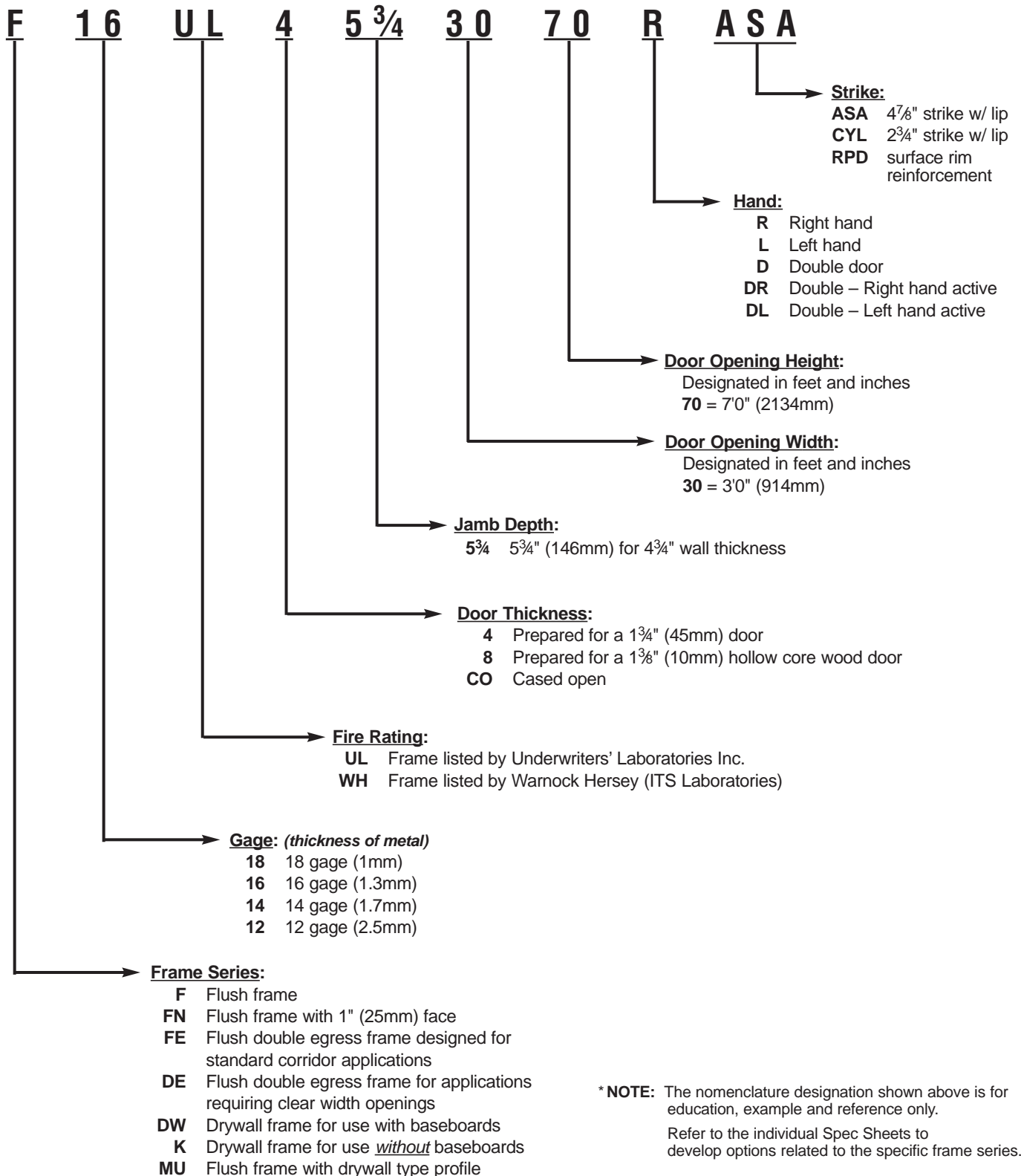

DOORS AND FRAMES with 1½ Pair of Hinges

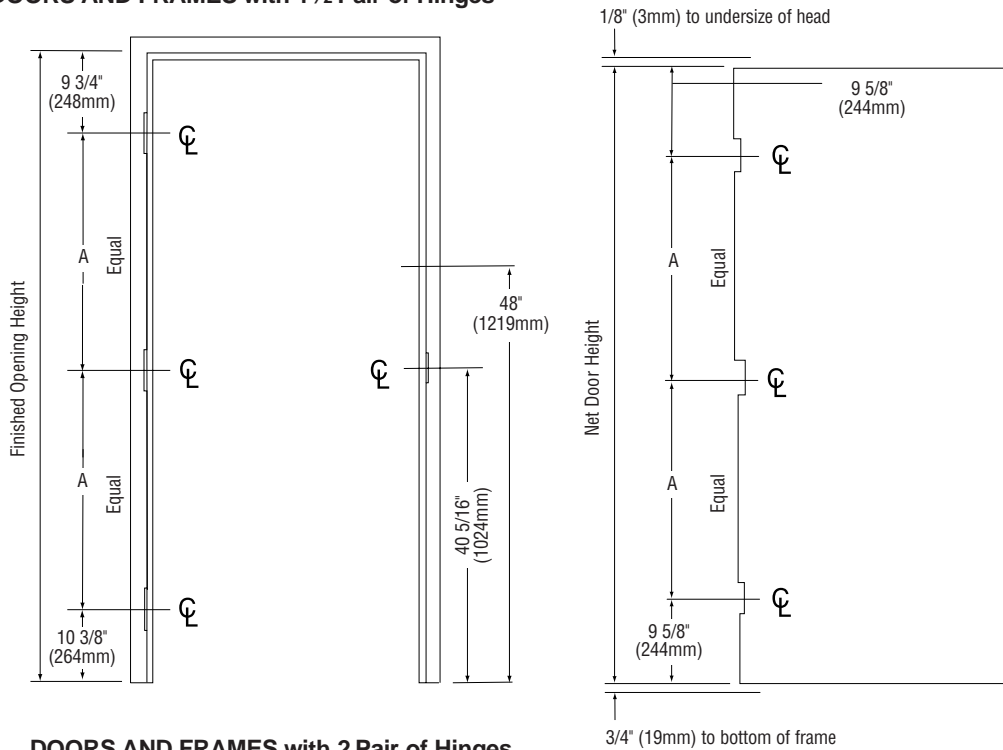

Chart 1

Door Opening Height	Dimension A
6'8" (2032mm)	29 ¹⁵ / ₁₆ " (760mm)
7'0" (2134mm)	31 ¹⁵ / ₁₆ " (811mm)
7'2" (2184mm)	32 ¹⁵ / ₁₆ " (7837mm)
7'6" (2286mm)	34 ¹⁵ / ₁₆ " (887mm)

* Net door height equals nominal door size minus 1/8" top clearance and 3/4" bottom clearance.

I.E. 6'8" nominal door
80"-1/8"-3/4"=79 1/8" net door size

DOORS AND FRAMES with 2 Pair of Hinges

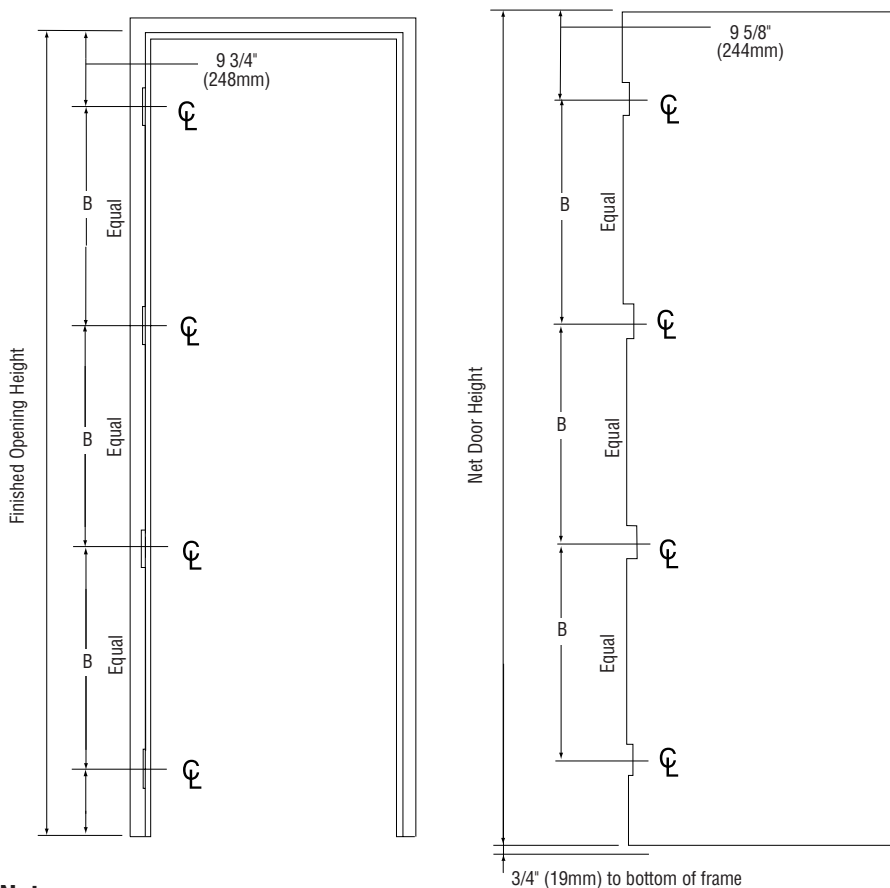

Chart 2

Door Opening Height	Dimension B
6'8" (2032mm) ¹	19 ⁶¹ / ₆₄ " (506mm)
7'0" (2134mm) ¹	21 ¹⁹ / ₆₄ " (541mm)
7'2" (2184mm) ¹	21 ⁶¹ / ₆₄ " (558mm)
7'6" (2286mm) ¹	23 ¹⁹ / ₆₄ " (592mm)
7'10" (2388mm)	24 ⁵ / ₈ " (625mm)
8'0" (2438mm)	25 ¹⁹ / ₆₄ " (643mm)
8'6" (2591mm)	27 ¹⁹ / ₆₄ " (693mm)
8'10" (2692mm)	28 ⁵ / ₈ " (727mm)
9'0" (2743mm)	29 ¹⁹ / ₆₄ " (744mm)
9'6" (2896mm)	31 ¹⁹ / ₆₄ " (795mm)
9'10" (2997mm)	32 ⁵ / ₈ " (829mm)
10'0" (3048mm)	33 ¹⁹ / ₆₄ " (846mm)

Notes:

1. Steelcraft standard hinge spacing for doors 5'0" including 7'6" (2286mm) high is 1½ pairs (3 hinges) as shown in chart 1. Information shown in Chart 2 is for reference when 4 hinges are specified for those door heights. Under 5'0" is 1 pair hinges.
2. Steelcraft standard hinge spacing for doors over 7'6" up to and including 10'0" high is 2 pair (4 hinges).
3. Steelcraft standard for doors over 10'0" (3048mm) is 2½ pairs (5 hinges).
4. For special door heights, dimensions A & B, will vary accordingly unless specified differently.

STEELCRAFT®

F16 AND F14-SERIES FLUSH FRAMES

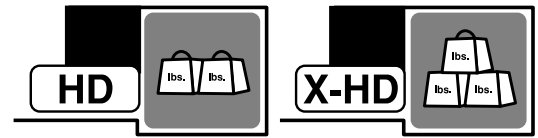

FLUSH FRAMES

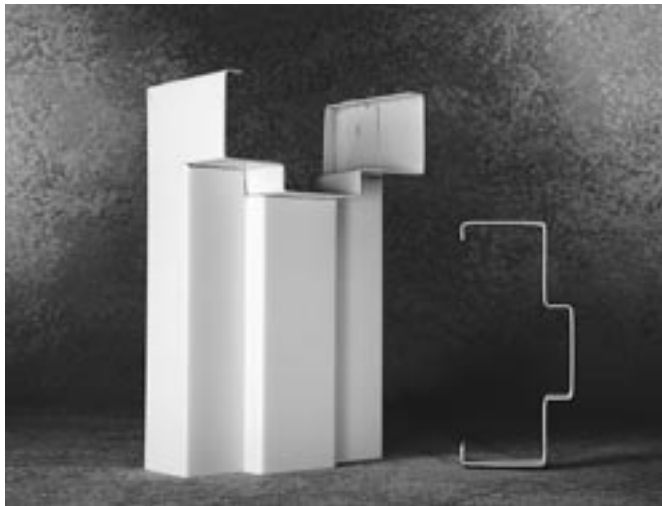

ABOUT THE PRODUCT:

The F16 and F14-Series 3-Sided Flush Frames are designed for heavy and extra-heavy duty applications in both commercial and institutional buildings. They can be installed in both interior and exterior locations, and in virtually all types of buildings and wall constructions. These frames are to be installed as part of the wall framing sequence. They can be specified and/or supplied as either KD (knock-down) for field assembly prior to installation, or SUA (set-up and welded) for installation as a pre-welded unit.

APPLICATIONS:

The F-Series Frames are typically used in the following types of wall constructions:

Wall Construction	Application	Typical Wall Anchors
Masonry	wrap or butted	Wire masonry
Existing masonry	butted	Bolted through soffit
Wood stud	wrap	Lock-in wood stud anchor
Steel stud	wrap	Lock-in steel stud anchor

Steel Thickness	Opening	Usage Frequency ¹	Applications
14 gage (1.7mm)	Interior & Exterior	Extra-heavy to Maximum duty	<ul style="list-style-type: none"> 16 & 14 gage steel doors
16 gage (1.3mm)	Interior & Exterior	Heavy to Extra-heavy duty	<ul style="list-style-type: none"> 20, 18 & 16 gage steel doors Commercial grade wood doors
Steel Type	Opening	Applications	
Non Galvanneal ³	Mainly Interior	<ul style="list-style-type: none"> Typical building conditions 	
Galvannealed ²	Mainly Exterior	<ul style="list-style-type: none"> Used in locations with high humidity and/or weather exposure 	

MATERIAL:

F-Series Frames are supplied from either 14 gage (1.7mm) or 16 gage (1.3mm) steel. Depending on environmental and usage conditions, the steel can be either non galvanneal or galvannealed. All frames are supplied with a factory applied baked on primer for ultimate field paint adhesion.

FEATURES AND BENEFITS:

Steelcraft F-Series Flush Frames offer the following unique features, which enhance long term functionality and durability:

- Die-mitered corner connections** (head/jamb) Standard corners insure attractive, tight and closed miters.
- Patented universal hinge preparations** allow for easy field conversion from standard weight (.134) hinges to heavy weight (.180) hinges.
- Adjustable base anchors** allow for installation adjustment when the floor is not level.
- Rubber silencers** are factory installed.
- Factory applied baked on rust inhibiting primer** in accordance with ANSI A250.10.

SPECIFICATION COMPLIANCE:

- Overall frame construction for the Steelcraft F16 and F14-Series Flush Frames meet the requirements of ANSI A250.8-1998 (commonly referred to as SDI-100).
- Hardware preparations and reinforcements are in accordance with ANSI A250.6-1997. Locations are in accordance with ANSI/DHI A115.

FIRE RATINGS:

The F-Series Frames meet the broadest fire rating requirements. They are listed for installations requiring compliance to both negative pressure testing (ASTM E152 and UL-10B) and positive pressure standards (UBC 7-2 and UL-10C). Refer to the "Fire Rated" section of the Steelcraft Spec Manual for particular listings.

¹ Usage frequency is based on ANSI A250.8-1998

² Reinforcements for galvannealed frames are also galvannealed

³ Commercial quality carbon steel

Details are subject to change without prior notice.

© 2000 Steelcraft Co.
Printed in USA

IR Security & Safety
Proven Source. Proven Solutions.™

Spec Manual
Rev. 5/2002

F1-1

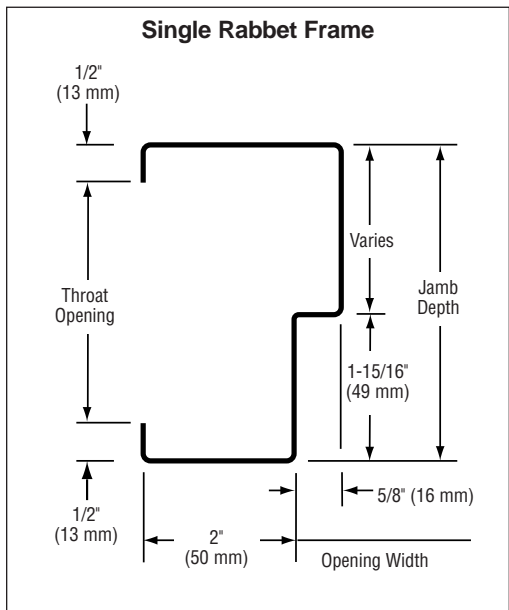
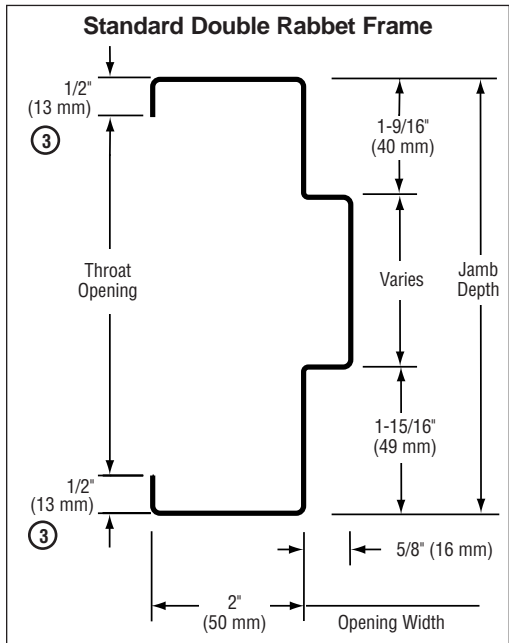
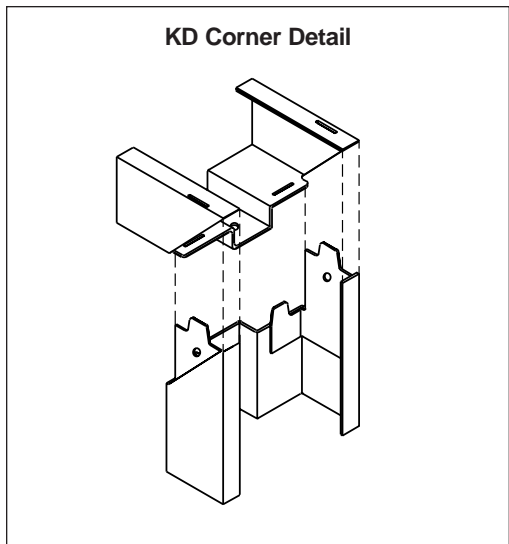
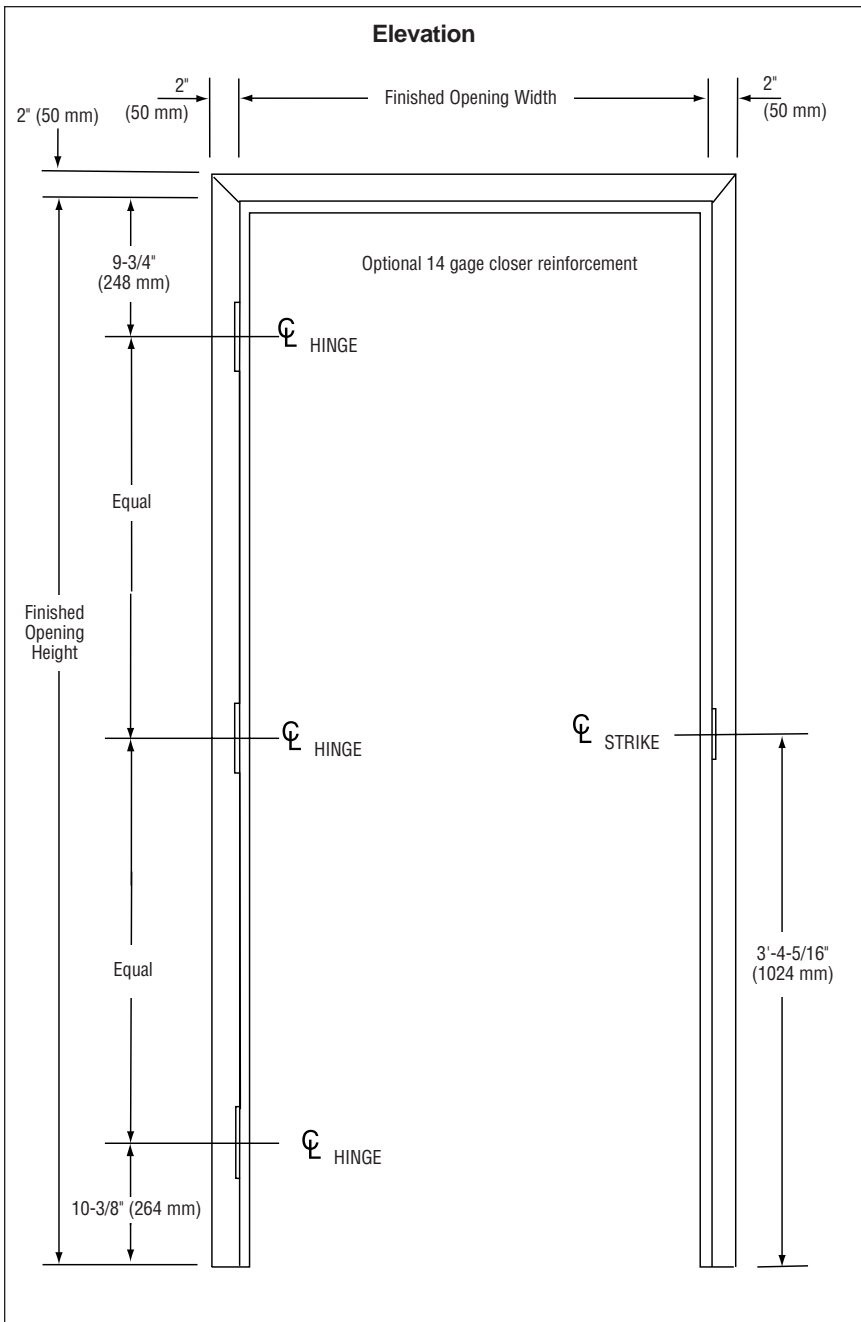

CONSTRUCTION NOTES:

- Door opening size maximum:**
 Single door opening size 5'0" x 11'0" (1524mm x 3353mm)
 Double door opening size 10'0" x 11'0" (3048mm x 3353mm)
- Jamb depths (profile) availability:**
Single rabbet:
 minimum = 3" (76mm)
 maximum = 20" (508mm)
Double rabbet:
 minimum = 4 3/4" (121mm)
 maximum = 20" (508mm)
- Standard profile dimensions (variations available):**
 Face = 2" (50mm)
 Stop = 5/8" (16mm)
 Returns = 1/2" (13mm) all frames except 5 3/4" (146mm) which is 7/16" (11mm)
- Standard die-mitered corners:**
 Four (4) concealed tabs interlocking head and jambs

Universal Mortise Hinge Prep

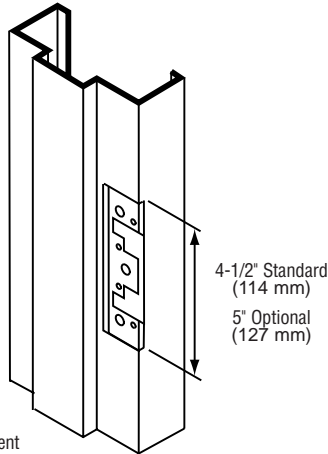

7 Gage Hinge Reinforcement

Optional 4" (102mm) Head Detail

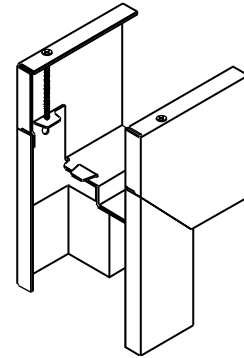

4 7/8" Strike Prep (ASA)

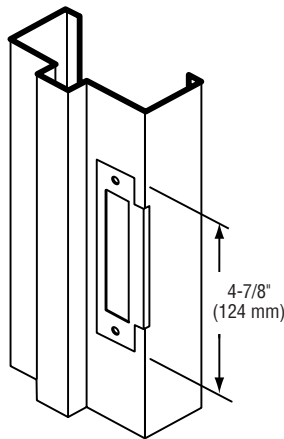

Welded Corner

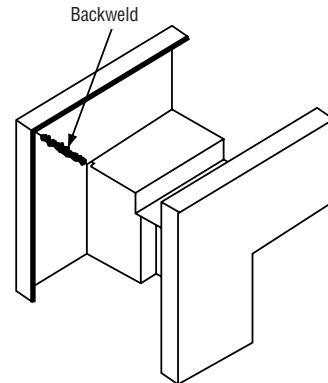

Rubber Silencer

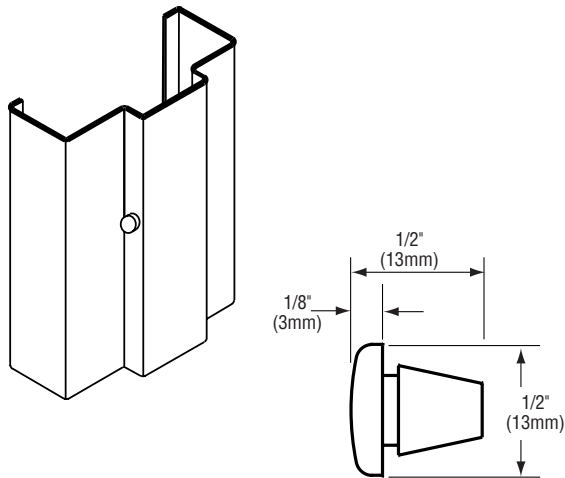

GENERAL NOTES:

1. **Frame profile** – variations in jamb depths available in 1/8" (3mm) increments:
 - **Single rabbet** – typically for walls less than 3 3/4" (95mm) thick (2" min.[50mm])
 - **Double rabbet** – typically for walls 3 3/4" (95mm) thick and over
2. **Corner connections:**
 - **KD (knock-down)** – Factory die-mitered
 - **Double rabbet frames** – 4 tabs per miter
 - **Single rabbet frames** – 3 tabs per miter
 - **Corner Connections – SUA (set-up and welded)**
Available when specified, and in accordance with ANSI A250.8-1998.
3. **4" (102mm) heads** – die mitered for use with 2" (50mm) face double rabbet jambs. Available when specified for KD or SUA applications.
4. **Standard hardware preparations:**
Standard mortised and reinforced with mortar guards for:
 - **Universal hinge preps** – 4 1/2" (114mm) patented preparation which allows easy and quick conversion from standard to heavy weight hinges.
 - **Strikes** – 4 7/8" (124mm) conforming to ANSI A115.1 and ANSI A115.2.
5. **Rubber silencers:** All frames are supplied with factory installed silencers to cushion the closing of the door and to eliminate the field problems related to installing the silencers after the frames are installed and grouted. Three (3) silencers per strike jamb and two (2) per double door head.

Wire Masonry Anchor

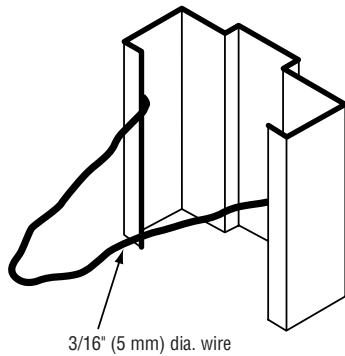

3/16" (5 mm) dia. wire

Existing Wall Anchor

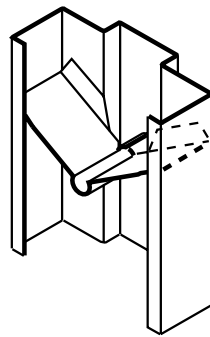

Adjustable Base Anchor

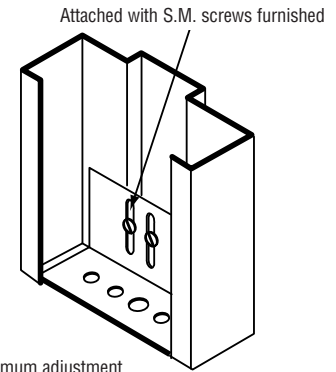

Maximum adjustment
1-3/8" (35 mm) below frame

Anchor for Stud Partitions

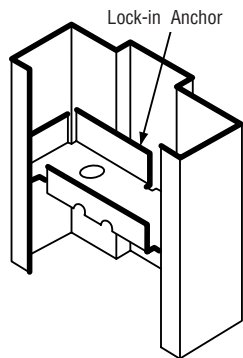

Lock-in Anchor

Anchor for Wood Stud Partition

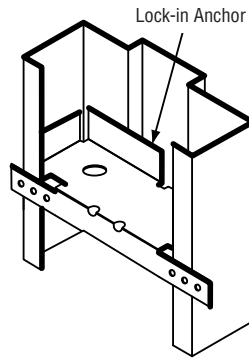

Lock-in Anchor

Universal Stud Anchor

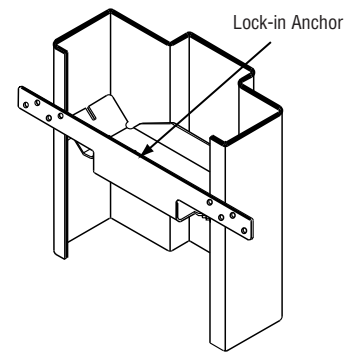

Lock-in Anchor

ANCHORING AND INSTALLATION NOTES:

1. F16 and F14-Series Commercial and Institutional

Frames are supplied standard with masonry wire or lock-in jamb anchors and adjustable base anchors. Anchors are designed for maximum wall/frame engagement and installation flexibility.

2. Anchoring applications:

- **Masonry wall** – Masonry wire anchors (3/16" [5mm] dia.) provide maximum engagements in mortar joints, and allow for full internal grouting during installation. Adjustable base anchors are attached directly to the floor and adjusted. The wall is built around the anchored frame. (Refer to installation sheet #INS-2004.)
- **Existing masonry walls (EMA)** – Specifically designed (18 Ga. steel) jamb anchors are used to add support for bolting the frame into the rough opening of an existing wall. An existing wall anchor is used as the base anchor in this application. (Refer to installation sheet #INS-2014.)
- **Wood stud walls** – Lock-in (18 Ga. steel) jamb anchors are designed to be attached to the wood stud rough opening. After the frame is anchored, the wallboard is installed and finished. (Refer to installation sheet #INS-2005.)
- **Steel stud walls** – Lock-in (18 Ga. steel) jamb anchors are designed to be attached to the webbing of the closed steel

studs which are built around the frame. Adjustable base anchors are attached directly to the floor and adjusted. After frame is anchored, the wallboard is installed and finished. (Refer to installation sheets #INS-2006 and 2007.)

3. **Special frame anchorage:** Frame anchorage details shown on this sheet are applicable to double rabbet frames with 2" (50mm) faces. Anchorage details and availability of lock-in anchors will vary with the following frame profile changes:
 - **Single rabbet** – all details will vary.
 - **Double rabbet** – over 8 3/4" (222mm) jamb depth
4. **Installation caution notice:** When temperature conditions necessitate an additive to be used in the plaster or mortar to prevent freezing, the contractor installing the frames shall coat the inside of the frames in the field with a corrosion resistant coating per SDI 105.
5. Installation shall conform to the published Steelcraft installations instructions, SDI 105 *Recommended Installation Instructions for Steel Frames*, and ANSI/DHI A115-IG *Installation Guide for Doors and Hardware*.
6. All fire rated frames must be installed in accordance with NFPA Pamphlet 80 and the *Authority Having Jurisdiction*.