



## Table of Contents

<b>Description</b>	<b>Page</b>
Introduction .....	2
Key Control Levels .....	3
Mechanical Overview.....	4
Rekeying	
When You Have The Existing Key.....	5
Master Keying.....	6
When You Have No Keys .....	7
Key Bitting Specs and Pin Lengths .....	8
Cutting Everest™ Keys on the Blue Punch.....	9
Upgrading to New Top Jaw.....	10
Tips for Cutting Everest Keys .....	11
Key Blanks and Keyways .....	12

## Introduction

Everest™ is the name given to a new family of patented key products by Schlage. Everest products are distinguished by the patented undercut groove milled into the right side of the key blade.

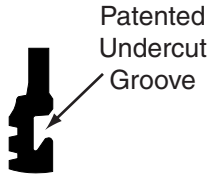

The first product in this family was the small format interchangeable core (SFIC) introduced in November 1998 to retrofit 7-pin Best® style IC products. A different service manual is devoted to that product (MS-C75).

The manual at hand covers the "full size" Schlage Everest cylinder, which is available in mortise, rim, key-in-knob and key-in-lever versions. The Everest full size cylinder is also available in Schlage's 23-030 full size interchangeable core.

Except for the keyway and special pin which checks for the lip on the side of the key section, Everest full size cylinders are virtually identical to Schlage Classic™ cylinders with the C keyway, which have been around since 1935.

Locksmiths, end users etc. get the benefits of the new patent without the need to invest in new pin kits, key machines or additional service equipment. However, a new top vise jaw is needed for the Blue Punch to hold all Everest C Family open key sections. A separate section of this manual provides details on how to upgrade old Blue Punches.

Note: D Family restricted keys cannot be cut reliably on a key biting punch because the top of the key blade is not straight.

## Larger Key Bow

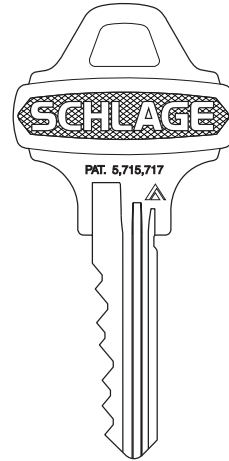

## Undercut Groove Keyway and Everest Logo on Plug Face

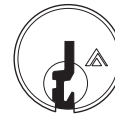

## Hole in Cylinder Shell Where Check Pin Locks into Place

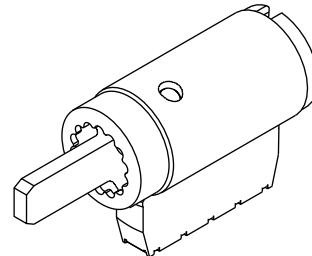

## Key Control

Since the late 1960's patents on keys have been used primarily to prevent unauthorized key duplication. This is the case with Schlage's new Everest™ D Family keyways but the C Family **open** keyways are a major departure from this tradition.

## Open Keyways

Everest C Family Keyways are protected by U.S. utility patents 5,715,717 and 5,809,816 against unauthorized manufacture and distribution. However, the C Family keyways are readily available to the end user for fast and easy key duplication **without any formalities**. All C keyways are considered "open" keyways which means they can be stocked and sold by all locksmiths and contract hardware dealers.

The purpose of the Everest C keyways is to guarantee the end user genuine Schlage quality replacement keys and to provide commercial locksmiths and contract hardware dealers a group of keyways not available in home centers or retail key stands.

Everest C Family keyways are the default keyways for new Schlage master key systems.

## Restricted Keyways

For end users who want restricted keys with patent protection, Schlage offers its Everest D Family keyways. Everest D Family keyways are protected by the same patents and require a letter of authorization from the end user. The difference between the C and D Families is just the keyway. Despite the fact that Everest D Family keyways are restricted keyways, they are still serviced in the same manner as the C Family keyways. However, D Family restricted keys cannot be cut reliably on a key biting punch because the top of the blade is not straight.



The keyway for each restricted D Family job is selected by Schlage and registered to the end user. Everest restricted key blanks, cut keys, cylinders and plugs are drop shipped directly to the end user (or a location specifically authorized by the end user). This creates positive key control by preventing dealers and distributors from having access to keys and cores without the end user's permission.

## Primus® Integration

Primus® cylinders are also available with Everest keyways. The Everest Primus keys are downward compatible to operate the conventional Everest cylinders covered in this manual. See the *Schlage High Security Cylinders & Key Control Service Manual* (SC-GN-1001) for details on Everest Primus cylinders.

A portion of the undercut groove is milled away on all *conventional* Everest keys to prevent them from being altered to operate an Everest Primus cylinder.

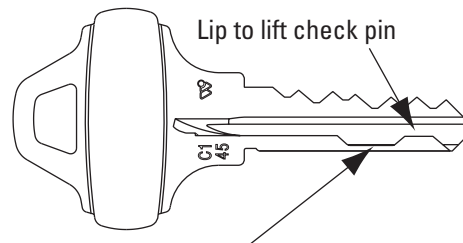

Lip removed to prevent Primus operation



These instructions assume that the reader already has basic experience pinning conventional cylinders.

The only thing different about Everest™ cylinders is the check pin and spring which are located in the special chamber on the bottom of the plug. If you are using a key to remove the plug, the key will hold both the check pin and the check pin spring in place.

### **Rekeying When You Have the Old Key (no master keying)**

- 1) Remove the cam, tailpiece or other type of plug retainer.
- 2) Insert the old key and turn it slightly in either direction.
- 3) Push the plug out gently with a plug follower.

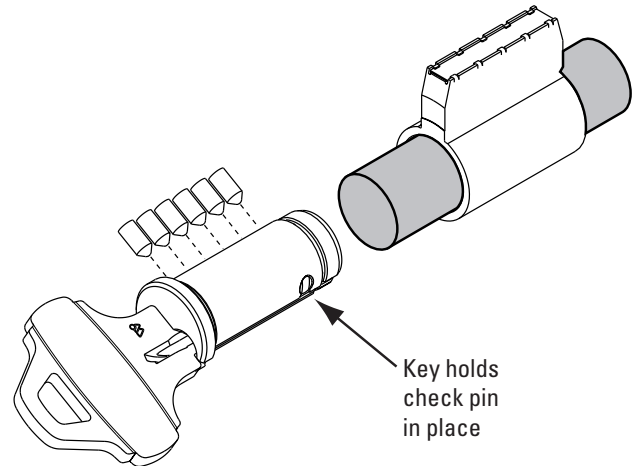

- 4) While the key is still in the plug to hold the check pin in place, discard the old pins.
- 5) Hold the check pin in the plug with your finger or thumb. Remove the old key and insert the new key.

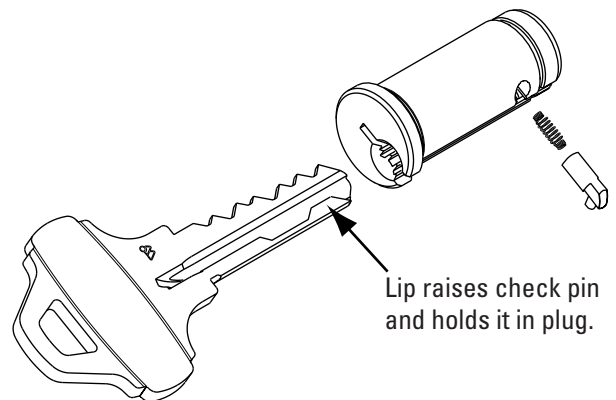

- 6) The new key will hold the check pin in place while you install the bottom pins and put the plug back into the shell.
- 7) Reinstall the cam, tailpiece, etc. and you're finished.

**Master Keying**

The master keying capacity of full size Everest™ cylinders is identical to that of Schlage Classic™ cylinders: 4,096 theoretical changes per keyway using two step progression. The MACS is 7.

When master keying Everest cylinders, Schlage recommends using a setup key to reinstall the loaded plug.

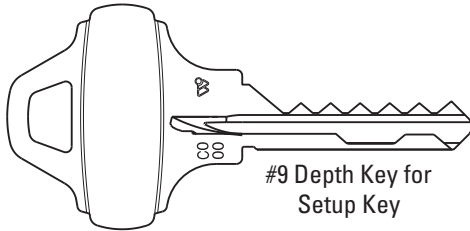

A setup key can be made by cutting a key blank to a 9 depth in all positions. If you remove the steeples between the cuts, the setup key can hold the check pin in place when removing the plug of a cylinder you had to shim.

- 1) Insert any operating key and turn it slightly in either direction. Gently push the plug out with a plug follower.

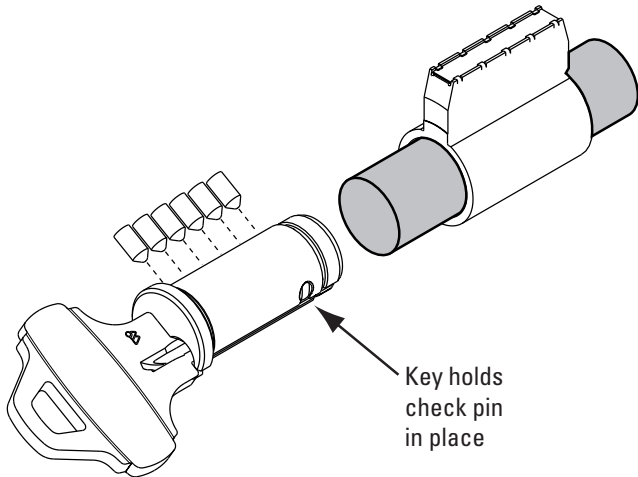

- 2) While the old key is still in the plug, discard the old pins.

- 3) Hold the check pin in position with your finger or thumb. Remove the old key and insert the setup key. If you are certain that the cylinder was not previously master keyed, skip to step 5.

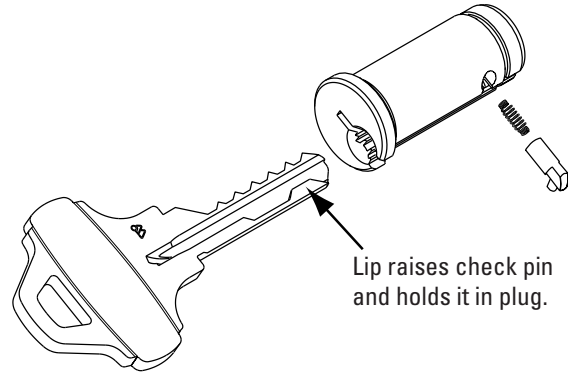

- 4) Clear the cylinder shell of any remaining master pins. This is extremely important. If master pins remain in the shell, you may experience the following problems:
  - A key cannot be inserted or removed.
  - One or more springs will get crushed and cause a future lockout.
  - Additional keys will operate the cylinder.

Slowly back the follower out of the shell. Replace any weak or damaged springs. Load the proper size top pins based on the plug total (bottom pin + any master pins). A plug follower with a groove will help you guide each spring and top pin into its chamber as you push the follower in from the back of the shell. (The 40-116 shell loading tool can make this process easier.)

- 5) Install new bottom and master pins into the plug.
- 6) Orient the plug so it is slightly turned with respect to the shell. Gently push the plug into the shell, pushing the plug follower out.
- 7) Test all keys for smooth operation.
- 8) Reinstall the cam, tailpiece, etc. and you're finished.

## Rekeying When You Have No Keys

When no key is available you can use standard locksmithing techniques to shim the cylinder open. However, the check pin must be taken into account. Follow these steps:

- 1) Using a pick or key blank, shim the six pins as usual. After the last pin is neutralized, the plug still cannot rotate or slide out because the check pin is engaged.
- 2) Leaving the shim in place, insert a setup key with no steeples between the 9 depth deep cuts. This unlocks the check pin and will also keep it from springing out of the plug in step 4.

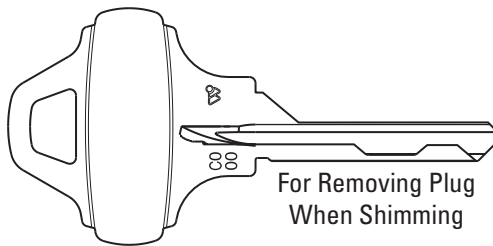

- 3) Use the setup key to turn the plug slightly in either direction and remove the shim.
- 4) Push the plug out gently with a plug follower.
- 5) While the setup key is still in the plug, discard the old pins. If you are certain that the cylinder was not previously master keyed, skip to step 7.

- 6) Clear the cylinder shell of any remaining master pins. This is extremely important. If master pins remain in the shell, you may experience the following problems:
  - A key cannot be inserted or removed.
  - One or more springs will get crushed and cause a future lockout.
  - Additional keys will operate the cylinder.

Slowly back the follower out of the shell. Load the correct size top pin in each chamber, based on the plug total (bottom pin + any master pins). A plug follower with a groove will help you guide each spring and top pin into its chamber as you push the follower in from the back of the shell. (The 40-116 shell loading tool can make this process easier.)

- 7) If you are master keying, leave the setup key in the plug. Otherwise, hold the check pin in position with your finger or thumb while you remove the setup key and insert the new operating key.
- 8) Install the new pins in the plug.
- 9) Orient the plug so it is slightly turned with respect to the shell. Gently push the plug into the shell, pushing the follower out.
- 10) Test all keys for smooth operation.
- 11) Reinstall the cam, tailpiece, etc. and you're finished.

### Key Bitting Specifications

Code Card  
**C45**  
for HPC 1200CM  
Code Machine

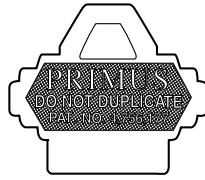

These specs are the same for Schlage Classic™ keys, including Primus®.

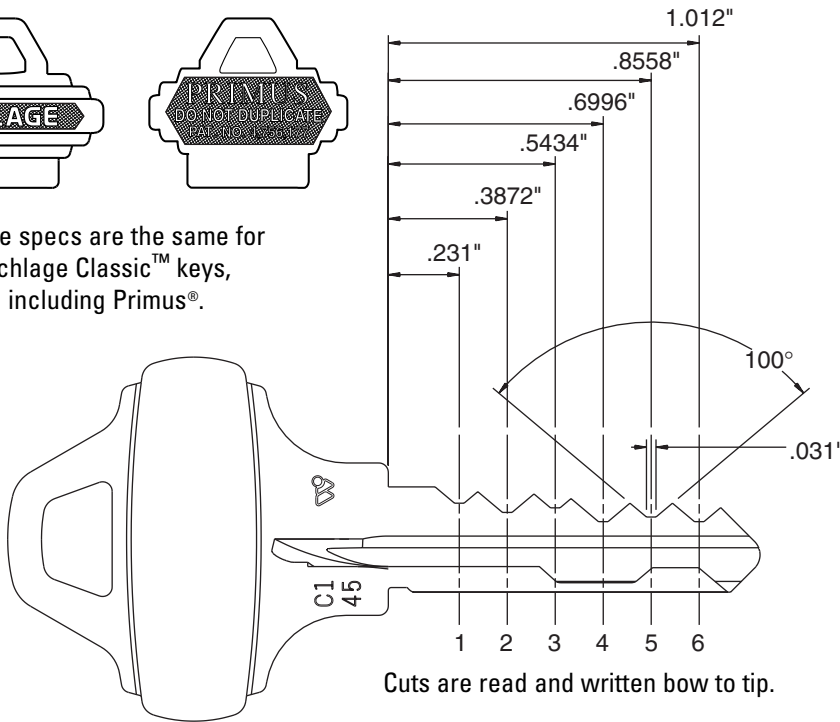

Cuts are read and written bow to tip.



### MACS = 7

Increment: .015"  
Progression: Two Step  
Blade Width: .343"  
Depth Tolerance: + .002" - 0  
Spacing tolerance: ± .001"

### Root Depths

0	.335"
1	.320"
2	.305"
3	.290"
4	.275"
5	.260"
6	.245"
7	.230"
8	.215"
9	.200"

### Pins & Springs

Bottom Pins			Master Pins			Top Pins				
Size	Length	Part No.	Size	Length	Part No.	Size	Length	Part No.	Application	
0	.165"	34-300	2	.030"	34-202	1	.235"	34-101	Plug total = 0, 1, 2, 3	
1	.180"	34-301	3	.045"	34-203	2	.200"	34-102	Plug total = 4, 5, 6	
2	.195"	34-302	4	.060"	34-204	3	.165"	34-103	Plug total = 7, 8, 9	
3	.210"	34-303	5	.075"	34-205					
4	.225"	34-304	6	.090"	34-206					
5	.240"	34-305	7	.105"	34-207					
6	.255"	34-306	8	.120"	34-208					
7	.270"	34-307	9	.135	34-209					
8	.285"	34-308					Other Pins and Springs			
9	.300"	34-309					Description		Part No.	
			Tumbler spring		C503-113					
			Check pin		34-007					
			Check pin spring		C603-951					
			Cap pin		C503-116					
			Cap pin spring		C503-115					

**Cutting Everest™ Keys on the Blue Punch**

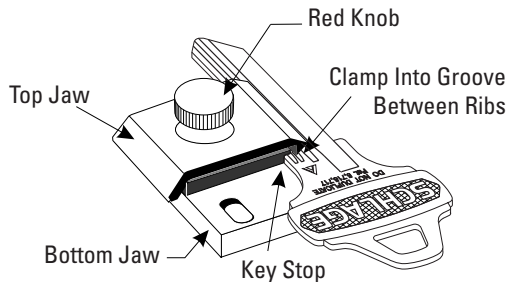
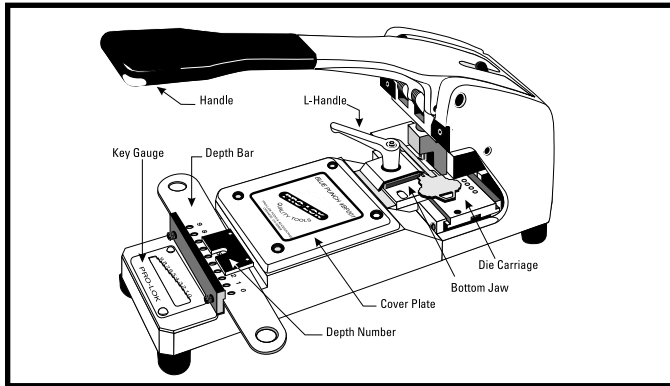

The original version of this popular key machine was developed in the mid-1970's. Pro-Lok® is the most recent in the succession of companies that have manufactured the machine. Even if you have what appears to be an original Schlage punch 40-126, it was made by one of the earlier companies. The basic principles are the same for all versions of the machine, but there are minor differences in the vise jaws which affect the machine's ability to cut Everest C Family keys.

Machines made before July 1999 were not designed to hold Everest keys. Most of these machines have a thin top vise jaw made of stamped steel. Some machines will hold Everest keys, except sections with "45" in the designation (such as C145). Even the first generation solid steel jaw was produced before Everest keys existed and must be replaced.

You may be able to alter your old style jaw by slightly elongating the hole, so it can travel far enough to engage in C145's groove. However, this solution should only be a temporary measure until you install the 40-074 upgrade package with the properly shaped top jaw.

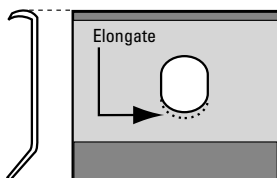

In the closeup illustrations of the vise, notice the different positions of the top jaw required to engage the grooves and seat the different shapes of Schlage key sections properly.

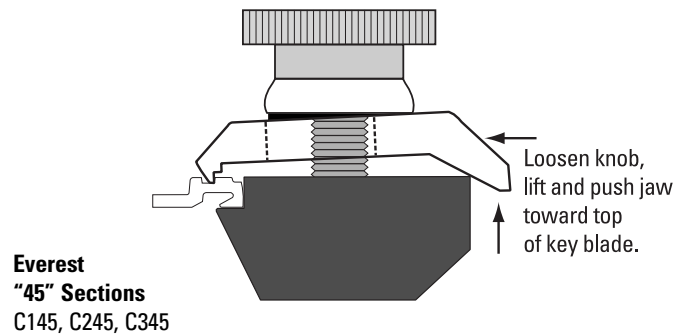
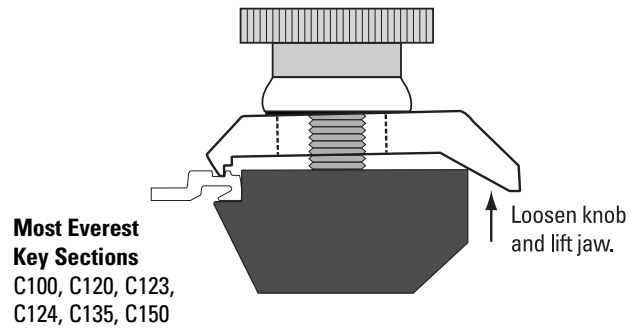
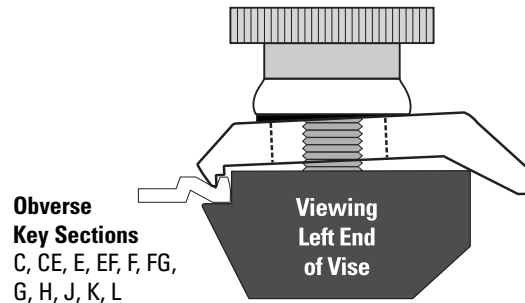

Not only must the top jaw engage in different places up and down the side of the various key sections, but the lever or knob screw must be tightened or loosened substantially. Loosening and tightening the lever or knob screw allows enough travel in the top jaw and to accommodate the difference in thickness between Classic™ and Everest key sections, and to adjust for the angles at which the top jaw sits.

## Upgrading to New Top Jaw

### Upgrade Package 40-074

Packages containing a newly designed top jaw, red knob, spring, finishing washer and regular washer can be obtained from your Schlage or Pro-Lok distributor.

Note that changing the top vise jaw has no effect on the accuracy of the machine. If your machine exhibits mechanical problems or cannot cut keys accurately, please contact your Pro-Lok distributor to arrange for your machine to be rebuilt.

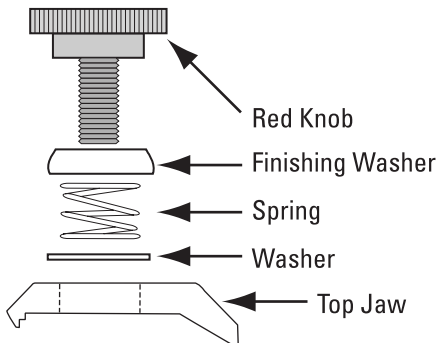

### Upgrading Machines Which Have a Red Knob

Installation on these machines is easy and the procedure is straightforward. Just unscrew the old knob, remove the old top jaw and install the new pieces. The only thing which needs explanation is the orientation of the new vise jaw because it is not symmetrical.

Install the jaw so the end with the longer angled portion is toward you. The end with the shorter angle has a lip to engage in the groove of the key section.

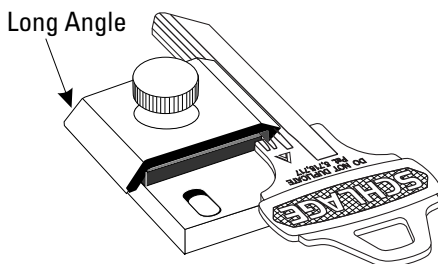

### The Black Lever – Advantages and Disadvantages

Pro-Lok changed the red knob to a black clutching lever in 1998, before Everest™ keys existed.



The lever can only swing about 180° before hitting the body of the machine. If you only use your Blue Punch to cut one type of Schlage key section, you can set the lever's travel for fast secure clamping every time.

Unfortunately, the black lever doesn't allow the top jaw to travel from its lowest position for Obverse keys to an intermediate position for clamping most of the Everest C Family keys, on up to the highest position required for C145. If you are a commercial locksmith and need to cut a variety of Schlage key sections daily, you may find the continuous lever adjustment cumbersome. On most machines, the lever must be specifically adjusted for each of the three clamping positions.

The cap screw inside the clutching lever is spring loaded. Lift the lever against spring pressure to disengage it from the screw. While disengaged, you should be able to swing the lever to the left or right without turning the screw. Let go of the lever and it snaps back into engagement with the screw. Use this procedure to back the screw out for Everest keys or to tighten the screw for Obverse keys.

The original red knob is more versatile. Simply tighten it down on the Obverse key sections or loosen it enough to let the top jaw move up to grab into the high groove of C145 – or anything in between.

### Upgrading Machines That Have a Black Lever

- 1) Swing the lever as far to the right as it will go. Lift up against spring pressure to disengage it from its screw.
- 2) Swing it back as far to the left as it will go and let it down to engage the screw.
- 3) Repeat this process as many times as necessary to unscrew the screw completely and remove the lever. An Allen wrench may be helpful.
- 4) Remove the lever, spring, washer and top jaw.

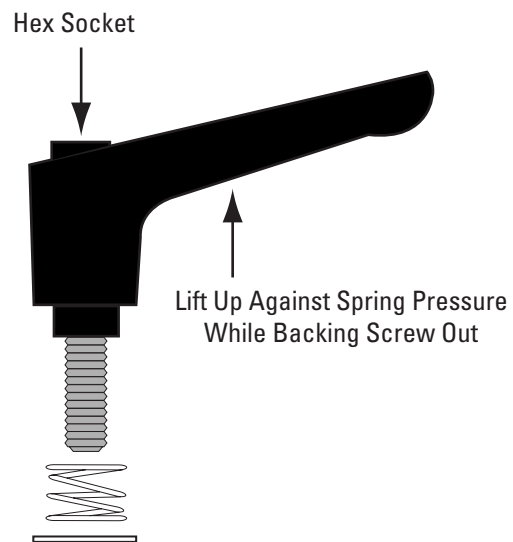

- 5) Install the new jaw so that the end with the longer angled portion is toward you. The end with the shorter angle engages the groove in the key milling.

You must now decide whether to use the red knob from your conversion pack or to reinstall the black lever. To help your decision, read the section under the heading **The Black Lever—Advantages and Disadvantages**. The red knob simply screws into place.

To install the black lever, it may be easier to use an Allen wrench to start the screw and then reverse the process you used to remove the lever. To adjust the lever's final position and rotation, you will need to clamp a sample key or key blank of the key section you plan to cut most frequently.

## Tips for Cutting Everest™ Keys

After you have cut several keys of each key section the procedure will be automatic. However, for your first few keys please observe these details:

- 1) Push the die carriage all the way to the right **before** you insert a key blank. If you clamp an Everest key before moving the carriage, its large bow may prevent the carriage from travelling far enough to let you make the first cut in the right position. You will begin in cut position #2 and mis-cut the key.
- 2) Closely observe the proper engagement of the top jaw into the key section. If the jaw clamps on the surface of a rib or into the very bottom relief in an Everest key, you may mis-cut the key because the jaw isn't able to square up the blank in the vise.

C124 and C135 have tiny grooves. Be sure jaw engages into a groove.

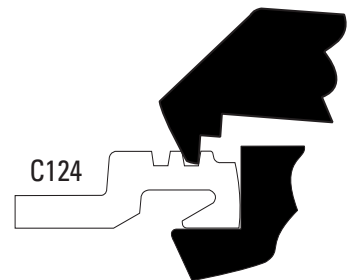

The position of the groove on C145, C245 and C345 blanks requires you to loosen the knob and push the jaw toward the cutter so it will engage the groove securely.

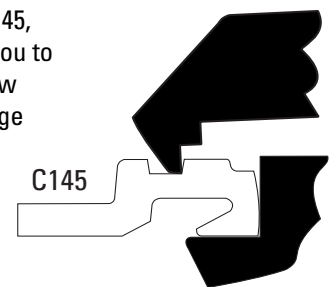

**SCHLAGE®** **Key Blanks**  
**EVEREST™**

**Operating  
Keys**

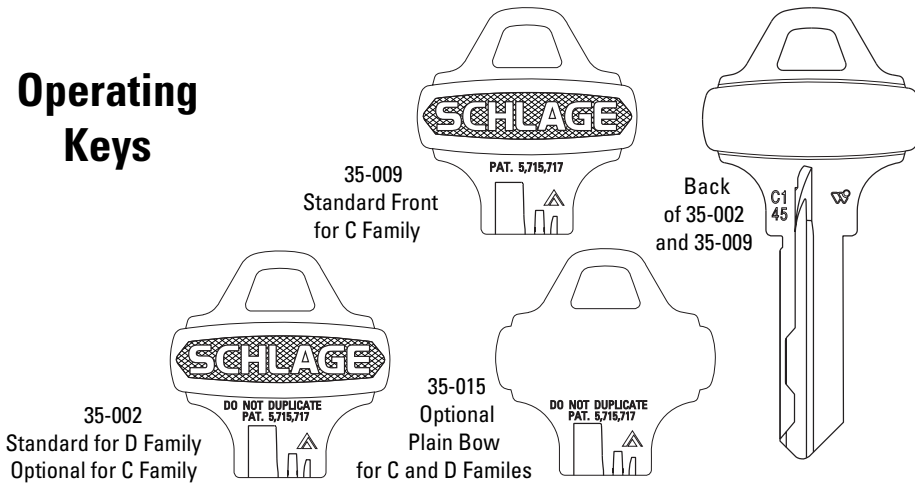

**Control  
Keys**

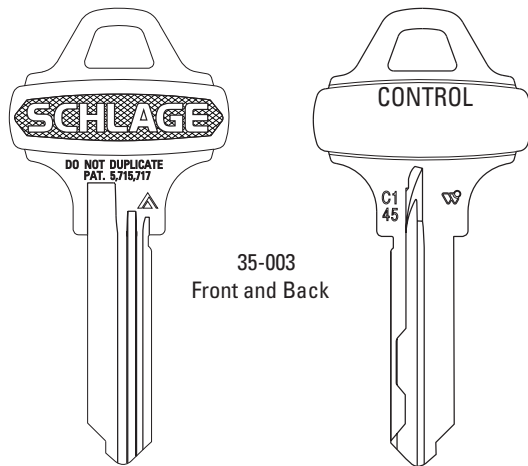

**Cut Keys**

To order cut keys, change the "35-" prefix to "48-" or "49-".

49- is used for factory master level keys, including control keys.

48- is used for change keys and random or stock cut keys.

**C Family  
Open Keyways**

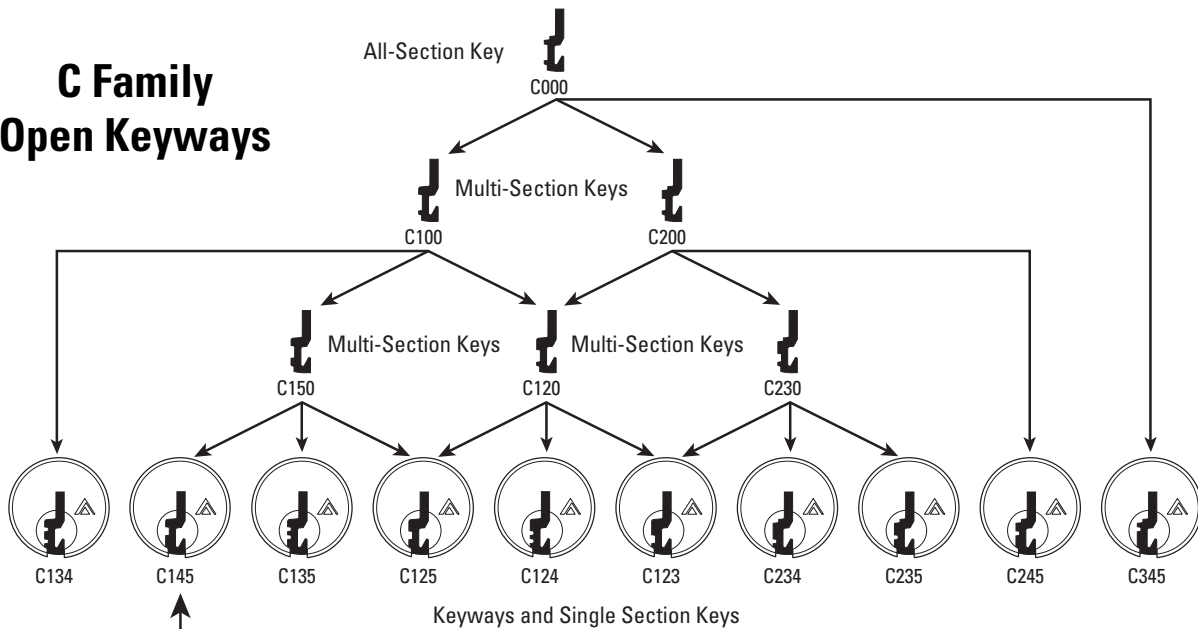

New key systems begin here and expand to the right.

---

**NOTES**

**NOTES**

---

**NOTES**

**NOTES**

  
**Administrative Offices**

1915 Jamboree Drive  
Colorado Springs, CO 80920  
(719) 264-5300  
FAX (719) 264-5382

**Commercial Customer Service**

2000 Sierra Point Parkway  
Brisbane, CA 94005-1850  
(800) 847-1864  
FAX (800) 452-0663  
FAX (800) 616-6040  
Order Entry  
(800) 452-0665

**Technical Services**

3899 Hancock Expressway  
Security, CO 80911  
(800) 847-1864  
FAX (719) 390-2682

**International Division**

Ingersoll-Rand Architectural Hardware  
1076 Lakeshore Road East  
Mississauga, Ontario, L5E 1E4, Canada  
(905) 278-6128  
FAX (905) 278-1413

**Internet**

<http://www.schlage.com>

