

# SCHLAGE®

## D-LOCK

A NEW STANDARD IN GRADE 1 SECURITY



**IR** Security & Safety  
Proven Source. Proven Solutions.™

**SCHLAGE®**  
Access Control and Key Systems Management

# D SERIES LEVERS

## Extra Heavy Duty Commercial

*D-Series locks are for commercial, institutional and industrial use, such as schools, hospitals and factories, where a long life of dependable operation must be combined with a high degree of resistance to physical abuse.*

*Popular functions of all lever designs are also available in Vandlgard®, where levers are free-wheeling in the locked position to resist more forceful attacks.*

## Performance Features

Tested to exceed 3,000,000 cycles, greatly exceeding the 800,000 cycle ANSI Grade 1 requirement.

Exceeds ANSI A156.2 Series 4000 Grade 1 locked lever torque requirements.

Vandlgard® functions have free-wheeling levers to resist force when locked.

Independent heavy duty spring cages for effective lever support.

Thru-bolted mechanism for positive interlock to door.

Concealed mounting screws.

Steel Latchbolt.

INDEX	
Cylinders	8
Designs & Finishes	4
Door Preparation	3
Door Handling	12
Exploded View	2
Functions	6 - 7
How to Order	13
Interchangeable Cores	8 - 9
Latches	10
Performance Features	2
Specifications	3
Strikes	11
Vandlgard® Features	5
Wiring for Electrified Locks	12

## Exploded View

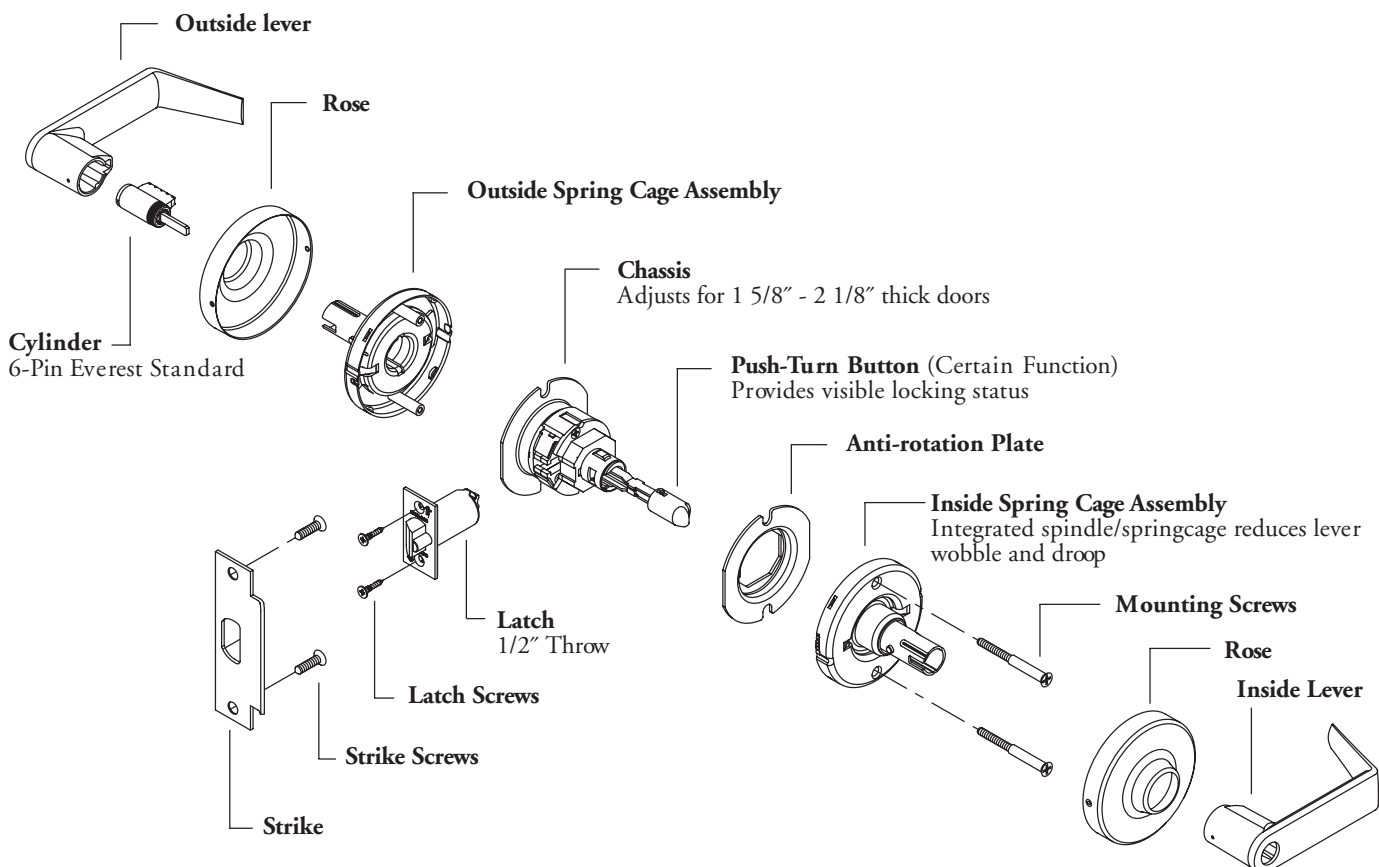

## Specifications

### Handing:

All D-Series lever locksets are non-handed.

### Door Thickness:

1 $\frac{3}{8}$ " to 2 $\frac{1}{8}$ " (41mm–54mm) standard including Vandlgard® functions.

See accessories (Page 12) for spacers required for 1 $\frac{3}{8}$ " doors.

### Backset:

2 $\frac{3}{4}$ " (70mm) standard. 2 $\frac{3}{8}$ ", 3 $\frac{3}{4}$ " and 5" (60mm, 95mm, 127mm) optional.

### Faceplate:

Brass, bronze or stainless steel. 1 $\frac{1}{8}$ " x 2 $\frac{1}{4}$ " (29 mm x 57mm) square corner, beveled.

### Lock Chassis:

Zinc plated for corrosion resistance.

### Latch Bolt:

Steel,  $\frac{1}{2}$ " (12mm) throw, deadlocking on keyed and exterior functions.  $\frac{3}{4}$ " (19mm) throw anti-friction latch available for pairs of fire doors.

### Exposed Trim:

Levers: Pressure cast zinc, plated to match finish symbols.  
Roses: Solid brass.

### Strike:

ANSI curved lip strike 1 $\frac{1}{4}$ " x 4 $\frac{7}{8}$ " x 1 $\frac{3}{16}$ " lip to center standard. Optional strikes, lip lengths and ANSI strike box available. See page 11.

### Cylinder & Keys:

6-pin Everest C123 keyway standard with two patented nickel silver keys per lock.

### Keying Options:

Interchangeable core and Primus® high security cylinders. Master keying, grand master keying and construction keying.

### Warranty:

Seven-year limited for all functions including Vandlgard®.

## Door Preparation

### Lever Designs

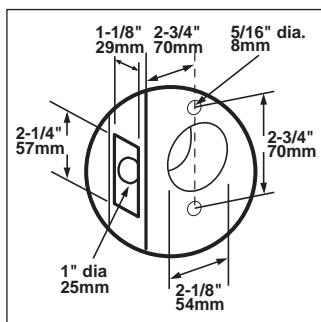

## Certifications

### ANSI

Meets or exceeds A156.2 Series 4000, Grade 1 strength and operational requirements. Meets A117.1 Accessibility Code.

### Federal

Meets FF-H-106C Series 161.

### California State Reference Code

(Formerly Title 19, California State Fire Marshal Standard)

All levers with returns comply; levers return to within  $\frac{1}{2}$ " of door face.

### UL / cUL:

All locks listed for A label single doors, 4' x 8'. Letter F and UL symbol on latch front indicate listing. Electrified functions are UL19X Listed for single point locking applications.

UL437 Listed locking cylinder optional: specify Primus 20-500 Series cylinder.



*Lever Designs & Finishes*

*Lever Designs & Finishes*

**ATHENS**  
 Symbol: ATH  
 Material: Pressure cast zinc lever; wrought brass rose  
 Finishes: 605, 606, 612, 613, 619, 625, 626





606 

**SPARTA**  
 Symbol: SPA (17)\*  
 Material: Pressure cast zinc lever; wrought brass rose  
 Finishes: 605, 606, 612, 613, 619, 625, 626



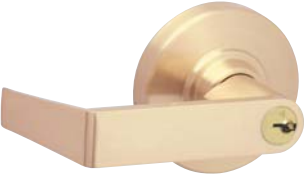
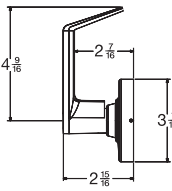

626 

**RHODES**  
 Symbol: RHO (06)\*  
 Material: Pressure cast zinc lever; wrought brass rose  
 Finishes: 605, 606, 612, 613, 619, 625, 626

612 

**OMEGA**  
 Symbol: OME\*  
 Material: Pressure cast zinc lever; wrought brass rose  
 Finishes: 605, 606, 612, 613, 619, 625, 626





619 

\* Trim available with CM5200 Series Locksets

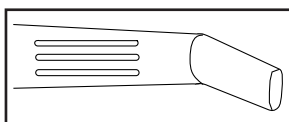

 Keyed functions available with interchangeable core options. Levers are available for full size and small format interchangeable cores.



**TACTILE WARNING (KNURLING)**

Change symbol designation as follows:

- 8AT** for Athens\*
- 8RO** for Rhodes
- 8SP** for Sparta

Only outside lever is knurled unless otherwise specified.

Not available with Omega trim

**Finishes**

- 605 Bright Brass
- 606 Satin Brass\*
- 612 Satin Bronze
- 613 Oil Rubbed Bronze
- 619 Satin Nickel
- 625 Bright Chromium Plated
- 626 Satin Chromium Plated

# D-SERIES WITH VANDLGARD™

Schlage D-Series keyed lever locks with Vandlgard provide vandal resistant technology. Designed for maximum accessibility, security and durability, Vandlgard sets the standard for door hardware in educational facilities and other applications subject to heavy traffic or abuse. The unique features of Vandlgard prevent damage to internal lock components caused by excessive force from persons kicking, hitting or standing on the lever to gain access. Vandlgard functions maintain total key system and architectural design compatibility with Schlage's regular D-Series cylindrical locks.

Levers have virtually replaced knobs in the marketplace for handicap accessibility. The added grip and leverage has created an increased opportunity for abuse or vandalism. This abuse often renders locks inoperable. In some cases the security of the door is violated leaving computer and laboratory equipment susceptible to theft. While this type of abuse is commonly associated with junior and senior high schools, it also occurs in universities, office buildings, commercial buildings, and public buildings.

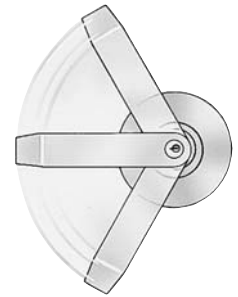

Locked lever freely rotates up and down while remaining securely locked. The Vandlgard function also increases resistance to over-rotation of the lever.

## *Benefits & Features*

### *Superb warranty.*

*All Vandlgard functions have a 7-year warranty.*

### *Reduce lever wobble and play.*

*Integrated spindle and spring cage greatly reduces lever sag and wobble.*

### *Resists vandalism.*

*Free-wheeling lever eliminates the ability to stand or exert excessive force on the end of the lever.*

### *Ease of installation.*

*Installs in under 2 minutes.*

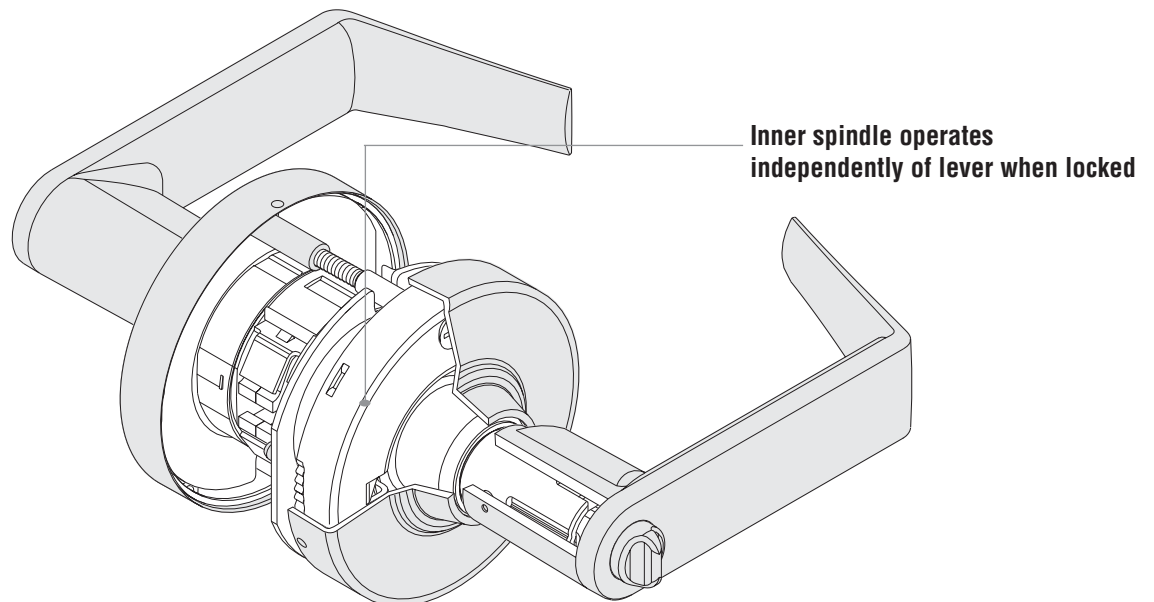

*D-Series Vandlgard levers comply with ADA requirements. &*

## Functions

### Non-Keyed Locks

SCHLAGE ANSI

**ND10S F75**

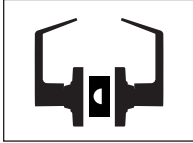

**Passage Latch**  
Both knobs always unlocked.

**ND12D F89**

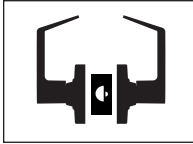

**Exit Lock**  
Outside lever always fixed. Inside lever always unlocked.

**ND12DEL**

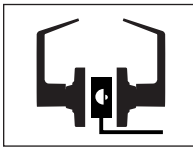

**Electrically Locked (Fail Safe)**  
Outside lever continuously locked electrically. Unlocked by switch or power failure. Auxiliary latch deadlocks latchbolt when door is closed. Inside lever always free for immediate exit.

**ND12DEU**

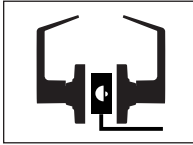

**Electrically Unlocked (Fail Secure)**  
Outside lever continuously locked until unlocked by electric current. Auxiliary latch deadlocks latchbolt when door is closed. Inside lever always free for immediate exit.

**ND25D**



**Exit Lock**  
Blank plate outside. Inside lever always unlocked.

**ND40S F76**

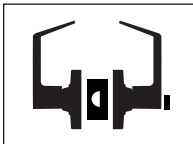

**Bath/Bedroom Privacy Lock**  
Push-button locking. Can be opened from outside with small screwdriver. Turning inside lever or closing door releases button.

**ND44S**

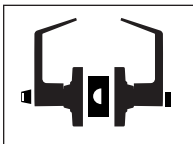

**Hospital Privacy Lock**  
Push-button locking. Unlocked from outside by turning emergency turn-button. Turning inside lever or closing door releases button.

**ND170**



**Single Dummy Trim**  
Dummy trim for one side of door. Used for door pull or as matching inactive trim.

### Keyed Locks

SCHLAGE ANSI

**ND50PD F82**

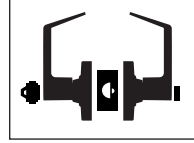

**Entrance/Office Lock\***  
Push-button locking. Push-button locks outside lever until unlocked with key or by turning inside lever.

**ND53PD F109**

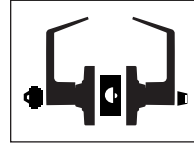

**Entrance Lock\***  
Turn/push-button locking; pushing and turning button locks outside lever, requiring use of key until button is manually unlocked. Push-button locking; pushing button locks outside lever until unlocked by key or by turning inside lever.

**ND60PD F88**

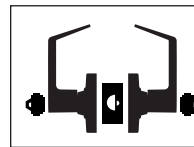

**Vestibule/Classroom Security Lock\***  
Latch retracted by key from outside when outside lever is locked by key in inside lever. Inside lever is always unlocked.

**ND66PD F91**

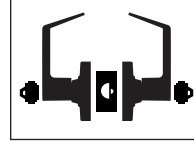

**Store Lock\*\*†**  
Key in either lever locks or unlocks both levers.

**ND70PD F84**

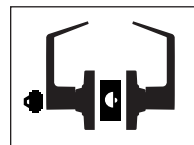

**Classroom Lock\***  
Outside lever locked and unlocked by key. Inside lever always unlocked.

**ND73PD F90**

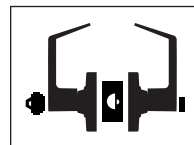

**Corridor Lock\***  
Outside lever locked by key outside or push-button inside. Push-button released by rotating inside lever or closing door. When outside lever is locked by key, key must be used to unlock it. Inside lever is always unlocked.

\* Available functions for small format interchangeable core.

† **Caution:** Double cylinder locks on residences and any door in any structure which is used for egress are a life safety hazard in times of emergency and their use is not recommended. Installation should be in accordance with existing codes only.

*Functions*

**Keyed Locks**

SCHLAGE ANSI

**ND80PD F86**

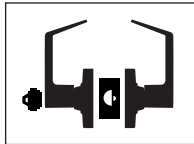

**Storeroom Lock\***  
Outside lever fixed. Entrance by key only. Inside lever always unlocked.

**ND80PDEL**

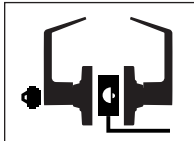

**Electrically Locked (Fail Safe)\***  
Outside lever continuously locked electrically. Unlocked by key outside or by switch or power failure. Auxiliary latch deadlocks latchbolt when door is closed. Inside lever always free for immediate exit.

**ND80PDEU**

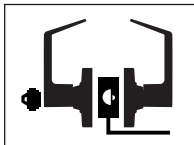

**Electrically Unlocked (Fail Secure)\***  
Outside lever continuously locked until unlocked by key or electric current. Auxiliary latch deadlocks latchbolt when door is closed. Inside lever always free for immediate exit.

**ND82PD F87**

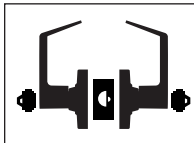

**Institution Lock\*†**  
Both levers fixed. Entrance by key in either lever.

**Vandlgard Functions**

SCHLAGE ANSI

**ND91PD F82**

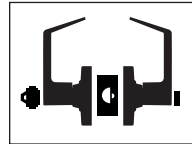

**Entrance/Office Lock\***  
Push-button locking. Push-button disengages outside lever until unlocked with key or by turning inside lever. Vandlgard is designed to disengage outside spindle from latch when in locked condition.

**ND92PD F109**

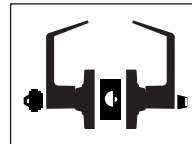

**Entrance Lock\***  
Turn/push-button locking; pushing and turning button disengages outside lever, requiring use of key until button is manually unlocked. Push-button locking; pushing button disengages outside lever until unlocked by key or by turning inside lever. Vandlgard is designed to disengage outside spindle from latch when in locked condition.

**ND93PD F88**

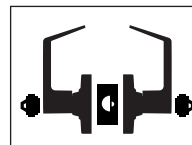

**Classroom Security Lock\***  
Latch retracted by key from outside when outside lever is disengaged by key in inside lever. Inside lever is always unlocked. Vandlgard is designed to disengage outside spindle from latch when in locked condition.

**ND94PD F84**

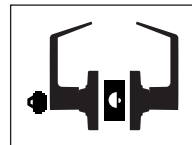

**Classroom Lock\***  
Outside lever disengaged and unlocked by key. Inside lever always unlocked. Vandlgard is designed to disengage outside spindle from latch when in locked condition.

**ND96PD F86**

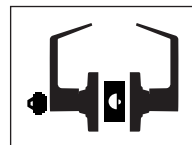

**Storeroom Lock\***  
Outside lever always disengaged. Entrance by key only. Inside lever always unlocked. Vandlgard is designed to disengage outside spindle from latch when in locked condition.

**ND96PDEL**

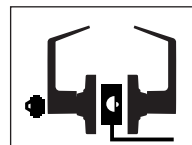

**Electrically Locked (Fail Safe)\***  
Outside lever continuously disengaged electrically. Unlocked by key outside or by switch or power failure. Auxiliary latch deadlocks latchbolt when door is closed. Inside lever always free for immediate exit. Vandlgard is designed to disengage outside spindle from latch when in locked condition.

**ND96PDEU**

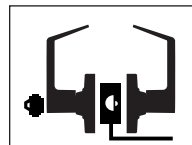

**Electrically Unlocked (Fail Secure)\***  
Outside lever continuously disengaged until unlocked by key or electric current. Auxiliary latch deadlocks latchbolt when door is closed. Inside lever always free for immediate exit. Vandlgard is designed to disengage outside spindle from latch when in locked condition.

\* Available functions for small format interchangeable core.

† **Caution:** Double cylinder locks on residences and any door in any structure which is used for egress are a life safety hazard in times of emergency and their use is not recommended. Installation should be in accordance with existing codes only.

*Standard Cylinders*

Schlage® locks are provided with cylinders precision built to extremely close tolerances and the highest standards of accuracy. Using only solid brass plugs, extruded brass shells, phosphor bronze springs, nickel silver keys and pins, ensures long life and ease of operation. For complete listing of cylinder parts, refer to the New D-Series Service Manual (SC-2058).

Conventional cylinders are available in Classic keyways or in patented Everest® keyways. Specify keyway to differentiate between Everest and Classic. Example: C (Classic) vs. C123 (Everest).

*Primus® High Security Cylinders*

Primus high security cylinders are available to add patented key control and varying degrees of geographical exclusivity to most Schlage 6-pin key systems, whether Everest or Classic keyways.

In addition to a conventional pin tumbler mechanism, Primus cylinders incorporate a patented finger pin and sidebar design providing a “dual-locking” cylinder that is virtually pick-proof. Resistance to drilling and other physical attack is optional by specifying 20-500 Series UL437 Listed cylinders.

Classic Primus cylinders are recommended for upgrading existing Classic key systems. Due to its extended patent life, the newly designed Everest Primus is recommended for new key systems and for upgrading existing Everest® key systems. Specify keyway to differentiate between Everest and Classic. Example: CP (Classic) vs. C123 (Everest).

**Cylinder for Most Functions**

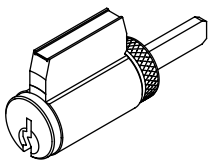

Tailpiece is vertical (shown) for levers.

**Cylinder Sleeve**

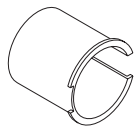

Cylinder Sleeve N523-100

**Standard Cylinders\***

Levers	Description
23-065	6-Pin conventional (standard)
20-765	Primus high security
20-565	Primus UL437 Listed high security
N123-041	Temporary construction plug, plastic for functions
N523-100	Cylinder sleeve

\*Available in 606 and 626 finish only. Everest C123 keyway standard.

*Full Size Interchangeable Core* 

Schlage® figure-8 interchangeable core (IC) locksets allow immediate rekeying at the door simply by using a special control key to replace the core.



Available in all lever designs, full size interchangeable cores can be integrated into any 5 or 6-pin Schlage key.

To order complete locks with full size cores, change suffix from PD to RD. Example: ND53RD. To order locks less core, change suffix to JD. To order with full size construction core, change suffix to TD.

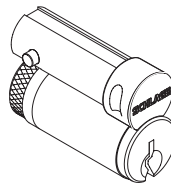

**Full Size Interchangeable Cores\***

Number	Description
23-030	Conventional core
20-740	Primus high security core

\*Available 606 and 626 finish only. Everest C123 keyway standard.

**Driver**  
N523-077

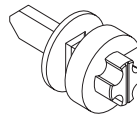

## Small Format Interchangeable Core

Available in all lever designs, the small format IC option is designed for Schlage Everest® B Family Restricted keyway cores and is also completely compatible with Best®, Falcon®, and other small format interchangeable cores.

To order complete locks with Everest B Family *Restricted keyway cores*, change product suffix from PD to GD and provide letter of authorization from end user. Example: ND53GD. To order locks less core, change suffix to BD. To order with keyed brass construction cores, change suffix to HD. To order with disposable plastic construction cores, change suffix to BDC.

### Small Format Core

### Disposable Construction Core

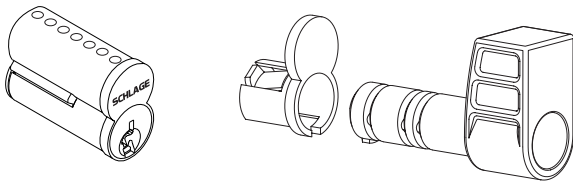

### Small Format Interchangeable Cores

Number	Description
80-036	7-Pin uncombined Everest B Family Restricted keyways
80-037	7-Pin combined Everest B Family Restricted keyways
80-043	6-pin uncombined Falcon / Best keyways
80-033	7-pin uncombined Falcon / Best keyways
M204-152	Disposable plastic construction core

Available 606 and 626 finish only. Specify keyway for existing systems.

80-033 and 80-043 cores are available in Best A, D, E, F, G, H, J, K, L, and M keyways. Specify keyway by suffixing "B" to keyway letter, e.g. "AB".

80-036 and 80-037 Restricted keyway cores require a letter of authorization from the end user. Schlage assigns the keyway when establishing new Everest Restricted key systems.

## IC Installation Tool

This tool is used to install the driver and retainer for full size IC in Schlage levers. Its other ends are designed to install and remove mortise cylinder housings and test mortise cylinder cam action for both small format and full size interchangeable core cylinders.

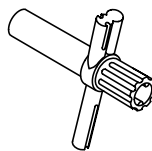

M504-413  
(Order separately.)

## Latches

D-Series latches are adjustable for flat or beveled edge doors. Latches and strikes are furnished in brass, bronze, or chrome finishes to be compatible with lock trim. When ordering, specify quantity, part number, and finish. All D-Series latches have 1/2" throw and 1" housings except 2 3/8" backset latches, which include sleeve G506-815 to fill a 1" edge bore. Standard latches are shown in bold type.

### Latches

Backset	Description	Deadlatch 1/2" Throw	Springlatch 1/2" Throw
<b>2 3/8"</b> 60mm	1 1/8" (29mm) x 2 1/4" (57mm) square corner	14-047	—
	1" (25mm) x 2 1/4" (57mm) square corner	14-048	—
<b>2 3/4"</b> 70mm	<b>1 1/8" (29mm) x 2 1/4" (57mm) square corner</b>	<b>13-047</b>	<b>13-048</b>
	1 1/8" (29mm) x 2 1/4" (57mm), 3/4" (19mm) throw for pairs of fire doors	14-042	—
<b>3 3/4"</b> 95mm	1 1/8" (29mm) x 2 1/4" (57mm) Square corner	14-028	14-010

### Deadlatch

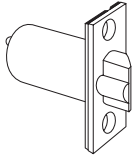

### Springlatch

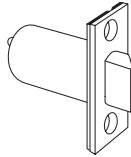

### 3/4" Throw Anti-Friction Deadlatch for Pairs of Fire Doors

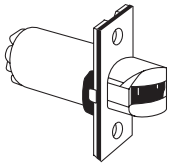

## Strikes

All Schlage strikes are furnished complete with screws. The standard D-Series strike has a 1 3/16" lip. When ordering separately specify quantity, product number, finish, and lip length. Standard strikes are shown in bold type.

### Strikes

Number	Lip Length	Description
10-013	1 1/8" (28mm)	1 1/8" x 2 3/4" (28mm x 70mm) Square corner, box 1 3/4" (38mm)
10-016	1 1/8" (28mm)	1 1/8" x 2 3/4" (28mm x 70mm), 3/4" (19mm) deep box for 14-042 fire door latch
<b>10-025</b>	<b>1 3/16" (30mm)</b> <b>1 3/8" (35mm)</b>	<b>1 1/4" x 4 7/8" (32mm x 124mm) ANSI</b>
K510-066	—	Box for 10-025 ANSI strike

### Long Backsets

D-Series locks with 5" backsets are normally furnished with 1 1/8" faceplates and 1" housings. Links installed in metal doors require one A501-567 sleeve (order separately) to join latch and link.

### Extension Link

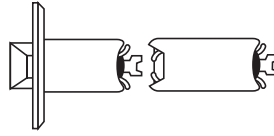

### Sleeve



(add to 2 3/4" backset latch)  
A501-567

### Latch Sleeve

Included with 2 3/8" backset latches to fill 1" edge bores.



### Door Reinforcement

Schlage 37-001 reinforcing kit is used to reinforce and help prevent the collapse of hollow metal doors when locksets are tightly mounted.

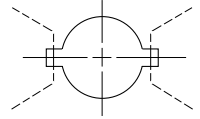

This kit should be used with long backsets for D-Series lock installations in hollow metal doors to prevent lateral movement of the latchbolt. Specify door thickness, 1 3/8" or 1 3/4", when ordering reinforcement kits.

### Reinforcement Kit

Sleeve  
A501-567

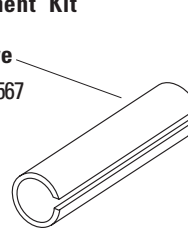

Reinforcement  
1 3/4" doors or  
1 3/8" doors

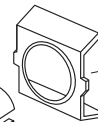

### ANSI Strike—Standard

10-025  
1 1/4" x 4 7/8" x 3/32"



### Square Corner Box Strike

10-013  
1 1/8" x 2 3/4" x 3/32"

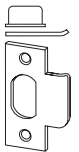

### Rabbeted Latch and Strike Kit

Rabbeted latch and strike kit finishes: 605, 626.

This kit adapts square corner latches and 2 3/4" (28mm) high strikes for 1/2" (13mm) rabbeted door and frame preparations.

### Rabbeted Latch and Strike Kit

39-030

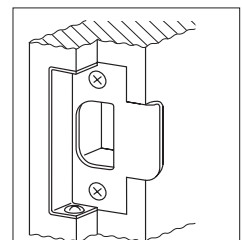
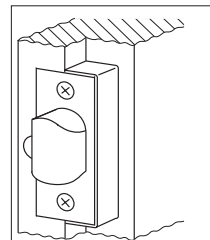

## Typical Wiring Diagram for Electrified Locks

### AC Power Source – EL or EU

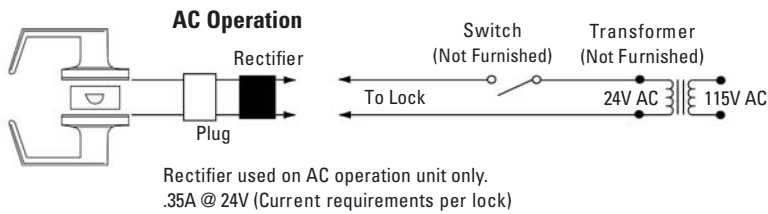

### DC Power Source – EL or EU

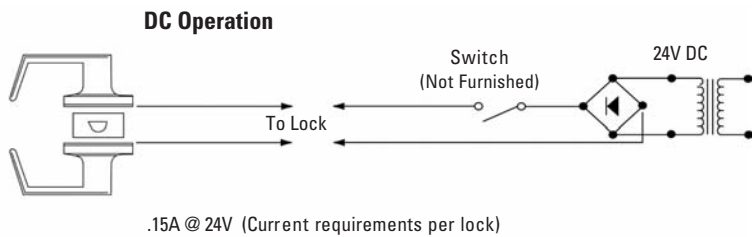

### AC and DC Application

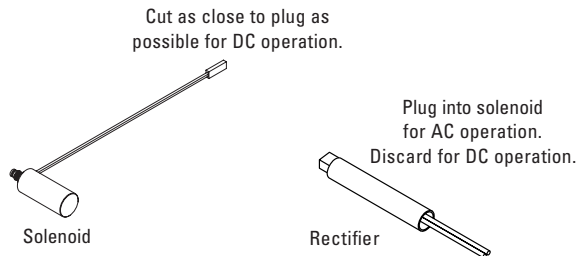

## Accessories

### 1-3/8" D-Series Lever Door Spacer



## Door Handing

All Schlage® locks are reversible. Hand information is necessary to ensure proper finish of latchbolt and strike for split-finish locks. Follow the diagram to determine the hand of the door. The outside is the secure side or the corridor side.

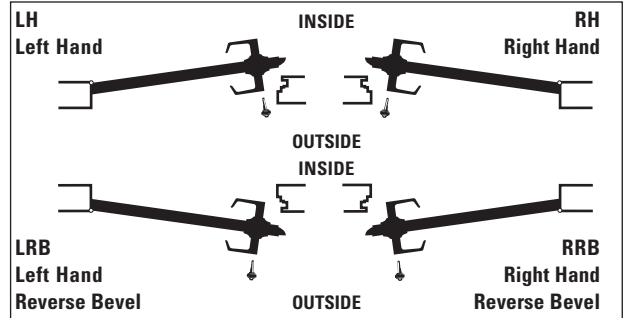

## How to Order D-Series Levers

To order Schlage® products, descriptive data should be in the same sequence as shown.

Line Item	Qty	Product	Outside		Inside		Hand	Latch	Strike	Door Thickness	Ext	Dim	Additional Details
			Des	Fin	Des	Fin							
1	2	3	4	5	6	7	8	9	10	11	12	13	14

- 1 Line item number
- 2 Quantity
- 3 Complete model number with function and cylinder type

To order cylinder options, change “PD” at the end of the model number as follows:

ND53PD Standard.

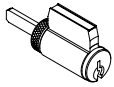

ND53LD Less standard cylinder. For Primus® cylinder, specify this option and order Primus cylinder separately.

ND53CD With temporary plastic construction cylinder. Double cylinder functions ordered *less cylinder* are furnished with these construction cylinders to maintain timing of key cams.

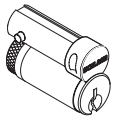

ND53JD Prepared for full size interchangeable core, less core. For Primus core, specify this option and order Primus core separately.

ND53RD With full size conventional interchangeable core installed. Order control keys separately.

ND53TD With full size (temporary) construction core installed. Order all keys separately.



ND53BD Prepared for small format (Falcon®, Best®, etc.) interchangeable core (SFIC), less core.

ND53GD With Everest® B Family restricted keyway small format core installed. Order control keys separately.

ND53HD With small format keyed brass construction core installed. Order all keys separately.

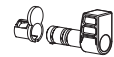

ND53BDC With small format disposable plastic construction core installed.

**4/5** Outside design / finish. Specify tactile warning (knurling) here as “8AT” for Athens®, “8RO” for Rhodes® or “8SP” for Sparta®.

**6/7** Inside design / finish. Leave blank if same as outside.

**8** Hand. Required for keyed knob designs and all split finish locksets. One hand per line item.

**9** Latch. Leave blank for standard or specify part number for optional latch. LLL=Less Latch.

**10** Strike. Leave blank for standard or specify part number for optional strike. LLL=Less Strike.

**11** Door thickness, if non-standard. Example: 200 = 2”.

**12** Extension, to specify whether thick door is extended inside (EI), outside (EO), differently (ED) or equally (EE).

**13** Dimension for strike lip lengths. See strike page for availability of specific dimensions with specific strikes.

100 = 1”

118 = 1 1/8”

114 = 1 1/4”

138 = 1 3/8”

112 = 1 1/2”

134 = 1 3/4”

200 = 2”

**14** Keying detail (e.g. key symbol, keyway, bitting) and other special requirements.

### EXAMPLE

Line Item	Qty	Product	Outside		Inside		Hand	Latch	Strike	Door Thickness	Ext	Dim	Additional Details
			Des	Fin	Des	Fin							
1	24	ND10S	SPA	605				10-013	214	EE			
2	4	ND50RD	RHO	613								138	C145 245793
3	60	ND93PD	ATH	626				14-047					E 000000

Note: Schlage order forms are available at no charge at [www.schlage.com/pricing/pricing.htm](http://www.schlage.com/pricing/pricing.htm).







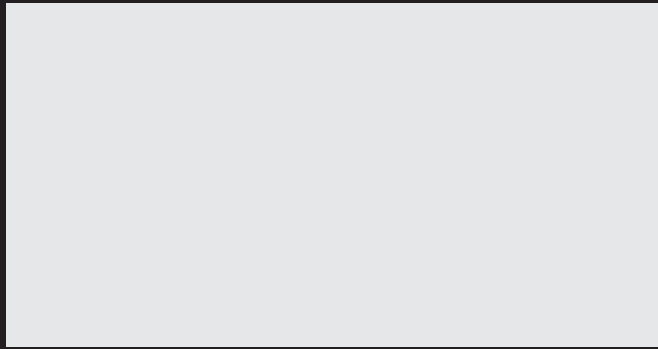

### **Administrative Offices**

111 Congressional Blvd.,  
Suite 200  
Carmel, IN 46032  
(800) 847-1864  
FAX (800) 452-0663

### **Commercial Customer Service**

2315 Briargate Parkway, Suite 700  
Colorado Springs, CO 80920  
(800) 847-1864  
FAX (800) 452-0663  
Order Entry  
FAX (800) 452-0665

### **Canada and Latin America**

Ingersoll-Rand Architectural Hardware  
1076 Lakeshore Road East  
Mississauga, Ontario, L5E 1E4, Canada  
(905) 403-1800  
FAX (905) 278-1413

### **North-East Asia**

23/F, 625 Kings Road  
Northpoint  
Hong Kong  
(852) 2235-0600  
FAX (852) 2265-1409

### **Internet**

<http://www.schlage.com>

### **Fax-On-Demand**

(888) 321-3228

### **Southeast Asia / Australia / NZ**

IR Architecural Hardware Ltd.  
P.O. Box 19-347  
437 Rosebank Road,  
Avondale, Auckland, New Zealand  
+64 (0) 9-829-0550  
FAX +64 (0) 9-829-0552

### **Mexico**

IR Security and Safety  
Blvd. Centro Industrial No. 11  
Pueñas de Vigag, Tlalnepantla  
Estado de Mexico, 54070 Mexico  
+525-5-8503-6614

### **United Kingdom**

IR Security and Safety Ltd.  
Bescot Crescent  
Walsall, West Midlands WS1 4DL  
United Kingdom  
+44 (0)1922 707400  
FAX +44 (0)1922 646303



### **Schlage**

111 Congressional Blvd., Suite 200  
Carmel, IN 46032  
800-847-1864  
800-452-0663 Fax  
[www.schlage.com](http://www.schlage.com)