

POWER OPERATORS

PRODUCT SELECTION GUIDE

LCN power operators are the proven standard in schools and health care facilities for over 20 years. They are easily retrofitted into existing doors and frames, as well as new construction. LCN low energy electrohydraulic and pneumatic power operators feature a heavy duty closer with a slow opening function. LCN's electromechanical power operators utilize a motor gearbox and control box to perform the opening and closing function.

LOW ENERGY POWERED SYSTEMS



CONCEALED MOUNT

2610 (PNEUMATIC)
2810 (ELECTROMECHANICAL)
2850 (ELECTROMECHANICAL)
2860 (ELECTROMECHANICAL)
2910 (ELECTROMECHANICAL)
2950 (ELECTROMECHANICAL)
2960 (ELECTROMECHANICAL)

SURFACE MOUNTED PULL SIDE

4630 (ELECTROHYDRAULIC)
4810 (PNEUMATIC)
9130 (ELECTROMECHANICAL)
9530 (ELECTROMECHANICAL)
9550 (ELECTROMECHANICAL)
9560 (ELECTROMECHANICAL)
9730 (ELECTROMECHANICAL)
9750 (ELECTROMECHANICAL)
9760 (ELECTROMECHANICAL)

SURFACE MOUNTED PUSH SIDE

4640 (ELECTROHYDRAULIC)
4820 (PNEUMATIC)
4840 (PNEUMATIC)
9140 (ELECTROMECHANICAL)
9150 (ELECTROMECHANICAL)
9540 (ELECTROMECHANICAL)
9550 (ELECTROMECHANICAL)
9560 (ELECTROMECHANICAL)
9740 (ELECTROMECHANICAL)
9750 (ELECTROMECHANICAL)
9760 (ELECTROMECHANICAL)

SURFACE MOUNTED DOUBLE EGRESS

9550 (ELECTROMECHANICAL)
9560 (ELECTROMECHANICAL)
9750 (ELECTROMECHANICAL)
9760 (ELECTROMECHANICAL)

HIGH ENERGY POWERED SYSTEMS

CAUTION High Energy Operators must be ordered with guide rails & safety devices.

CONCEALED MOUNT

2510 (ELECTROMECHANICAL)
2550 (ELECTROMECHANICAL)

SURFACE MOUNTED PULL SIDE

9330 (ELECTROMECHANICAL)
9350 (ELECTROMECHANICAL)

SURFACE MOUNTED PUSH SIDE

9340 (ELECTROMECHANICAL)
9350 (ELECTROMECHANICAL)

SURFACE MOUNTED DOUBLE EGRESS

9350 (ELECTROMECHANICAL)

Note: LCN offers manual closers that have reduced opening force to meet ADA requirements. See applicable catalog section.

POWER OPERATORS

PRODUCT COMPARISON - ELECTROHYDRAULIC/PNEUMATIC PRODUCT COMPARISON

This chart shows a basic features comparison of the LCN electrohydraulic and pneumatic power operator systems designed to provide easy access without sacrificing closing power. Refer to the specific closer chapter for complete details.

CLOSER SERIES	MOUNTING				FINISH		COVER		CYLINDER			*ARM FUNCTION						
	TOP JAMB (PULL SIDE)	TOP JAMB (PUSH SIDE)	PARALLEL ARM	CONCEALED	POWDER COAT	PLATED	PLASTIC	METAL	NON-HANDED	NON-SIZED	ACCESSIBILITY*	POWER OPERATOR	HOLD-OPEN	STANDARD (SINGLE)	REGULAR (DOUBLE)	EXTRA DUTY ARM	CUSH-IN-STOP	SPRING CUSH
2610	○	○	○	●	●	●	○	●	○	○	♿	●	○	90°	○	○	○	○
4630	●	○	○	○	●	●	○	●	●	●	♿	●	●**	90°	○	○	○	○
4640	○	●	○	○	●	●	○	●	●	●	○	●	●**	○	90°	○	○	○
4810	●	○	○	○	●	●	○	●	●	●	♿	●	○	90°	○	○	○	○
4820	○	●	○	○	●	●	○	●	●	●	○	●	○	○	90°	○	○	○
4840	○	○	●	○	●	●	○	●	●	●	♿	●	○	○	○	90°	90°	90°

- AVAILABLE
- NOT AVAILABLE

♿ Closer available with less than 5.0 lbs. opening force on 36" door.
 * See individual series for maximum manual opening.
 ** Switch provided for continuous Hold-Open.

PRODUCT COMPARISON - ELECTROMECHANICAL PRODUCT COMPARISON

This chart shows a basic features comparison of the LCN electromechanical power operator systems designed to provide easy access without sacrificing closing power. Refer to the specific operator chapter for complete details.

OPERATOR SERIES	MOUNTING						HANDING		FINISH		COVER		ARM FUNCTION				
	SURFACE MOUNT SINGLE DOOR	SURFACE MOUNT SIMULTANEOUS PAIR	SURFACE MOUNT INDEPENDENT PAIR	CONCEALED SINGLE DOOR	CONCEALED SIMULTANEOUS PAIR	CONCEALED INDEPENDENT PAIR	HANDED	NON-HANDED	STANDARD ANODIZED	CUSTOM ANODIZED	CUSTOM PAINT	METAL	STANDARD (SINGLE)	REGULAR (DOUBLE)	DOUBLE EGRESS (PUSH/PULL)	OFFSET PIVOT ARM	CENTER PIVOT ARM
2510	○	○	○	●	○	○	●	○	○	○	○	○	○	○	○	○	○
2550	○	○	○	○	○	○	●	○	○	○	○	○	○	○	○	○	○
2810	○	○	○	○	○	○	●	○	○	○	○	○	○	○	○	○	○
2850	○	○	○	○	○	○	●	○	○	○	○	○	○	○	○	○	○
2860	○	○	○	○	○	○	●	○	○	○	○	○	○	○	○	○	○
2910	○	○	○	○	○	○	○	○	○	○	○	○	○	○	○	○	○
2950	○	○	○	○	○	○	○	○	○	○	○	○	○	○	○	○	○
2960	○	○	○	○	○	○	○	○	○	○	○	○	○	○	○	○	○
9130	○	○	○	○	○	○	○	○	○	○	○	○	○	○	○	○	○
9140	○	○	○	○	○	○	○	○	○	○	○	○	○	○	○	○	○
9150	○	○	○	○	○	○	○	○	○	○	○	○	○	○	○	○	○
9330	○	○	○	○	○	○	○	○	○	○	○	○	○	○	○	○	○
9340	○	○	○	○	○	○	○	○	○	○	○	○	○	○	○	○	○
9350	○	○	○	○	○	○	○	○	○	○	○	○	○	○	○	○	○
9530	○	○	○	○	○	○	○	○	○	○	○	○	○	○	○	○	○
9540	○	○	○	○	○	○	○	○	○	○	○	○	○	○	○	○	○
9550	○	○	○	○	○	○	○	○	○	○	○	○	○	○	○	○	○
9560	○	○	○	○	○	○	○	○	○	○	○	○	○	○	○	○	○
9730	○	○	○	○	○	○	○	○	○	○	○	○	○	○	○	○	○
9740	○	○	○	○	○	○	○	○	○	○	○	○	○	○	○	○	○
9750	○	○	○	○	○	○	○	○	○	○	○	○	○	○	○	○	○
9760	○	○	○	○	○	○	○	○	○	○	○	○	○	○	○	○	○

- AVAILABLE
- NOT AVAILABLE



Note: Series 2510, 2550, 9330, 9340, 9350 are high-energy products & must be ordered with guide rails and safety devices.

WHAT IS THE ADA?

The ADA is a civil rights law, not a building code. This act is designed to provide protection for people with disabilities. The law is divided into four major titles that prohibit discrimination against the disabled in Employment, Title I, Public Services and Transportation Title II, Public Accommodations Title III, and Telecommunications Title IV. Title III concerns doors and door controls.

WHAT IS THE INTENT OF ADA, TITLE III?

Essentially, owners of certain types of buildings must remove barriers and provide people with disabilities with access equal to, or similar to, that available to the general public. The deadline for compliance was January 26, 1992.

The final rules implementing Title III were published in the Federal Register of July 26, 1991. To obtain a copy or ask questions, contact the U.S. DEPARTMENT OF JUSTICE. Technical information can be obtained from The U.S. ARCHITECTURAL AND TRANSPORTATION BARRIERS COMPLIANCE BOARD.

HOW DOES ADA AFFECT DOORS?

The ADA defines an "accessible" opening which means, among other things, providing a door with a minimum 32" (813 mm) clear opening, easily manipulated handles, a maximum opening force, a minimum closing time, and capable of opening to at least 90°.

ADA criteria, based on OPENING FORCE, are similar to American National Standards Institute (ANSI) Standard A117.1. This is different from ANSI Standard A156.4, which is based on CLOSING FORCE.

WHAT ARE THE OPENING FORCE LIMITS?

DOOR TYPE	OPENING FORCE
Fire Rated	Note 1
Interior Non-Fire-Rated	5.0 lbs. (22.2 N)
Exterior Non-Fire-Rated	"Reserved", Note 2

Note 1: All fire rated doors should have the minimum opening force allowable by the appropriate administrative authority, typically the local Fire Marshal. Closing and latching a fire door takes precedence over ADA opening force limits.

Note 2: The exterior door limit is "Reserved" (an undefined term), although the 8.5 pounds (37.8 N) maximum force recommended in ANSI Standard A117.1-1986 is commonly used.

HOW IS THE DOOR MEASURED?

Two ADA criteria affect the door closer selection, adjustments, opening force, and time to close. Since the law does not clearly define the method of measurement, this is LCN's recommendation.

1. On the push side of the door, locate a point at the center line of the push plate/lock trim or 30" (762 mm), from the hinge edge of the door, whichever is greater.
2. Mark the floor at a point where the push side of the doors' latch stile is at 70°. Mark a second point where the push side is 3" (76 mm) from the latch.
3. Open the door so the latch is clear of the strike and the door is slightly off the stop.
4. Using a force gauge on the mark determined in Step #1, push the door open to the 70° mark established in Step #2. Observe the force readings. (Accuracy of the readings varies with the gauge quality.)
5. Adjust the closer spring power to meet the maximum opening force.
6. Hold the door at the 70° mark. Release the door and time the closing sweep between the two marks.
7. Adjust the closer main speed regulation valve to obtain a minimum 3 second "time to close".

NOTE: Delayed action closers are not necessary to meet the ADA 3 second "time to close" requirement but do offer additional time for people to pass through the door.

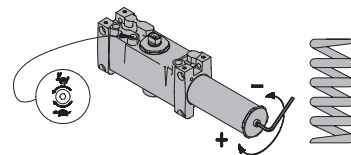

CAUTION! Any manual door closer, including those certified by BHMA to conform to ANSI Standard 156.4, that is selected, installed, and adjusted based on ADA

requirements may not provide sufficient power to reliably close and latch a door. Auto-Equalizer systems offer an alternate solution.

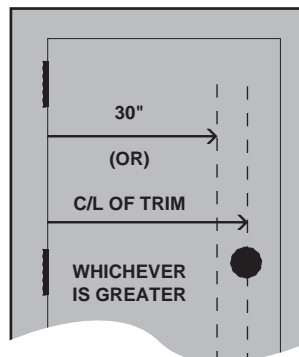

POWER OPERATORS

WHAT ARE THE CHOICES FOR ADA COMPLIANT DOOR CONTROLS?

LCN offers both surface and concealed mountings for powered systems or manual closers.

POWERED SYSTEMS

LCN Power Operator Systems offer easy access for the disabled and resolve the problem of obtaining reduced opening force while providing adequate closing force.

MANUAL CLOSERS

Manual closers rely on reduced spring power to meet opening force requirements. Four principle factors affect the performance of manual closers:

1. DOOR WIDTH:

A wider door provides more leverage for the user, thus reducing the opening force required.

2. SPRING POWER:

Adjusting spring power to achieve a lower opening force also reduces the closing force available.

3. ARM SELECTION:

The superior mechanical advantage of a regular arm system offers the user significantly lower average opening forces through the 70° measurement range compared to a standard arm (track type) closer. Regular arms also provide superior latching power.

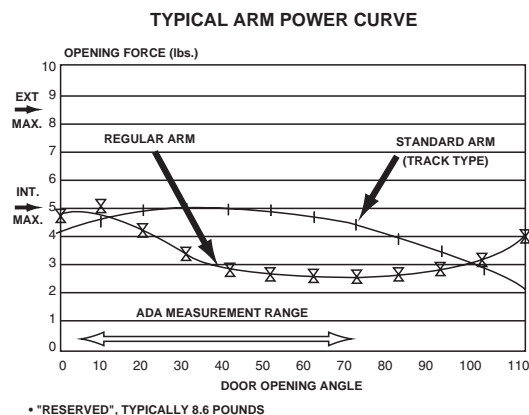
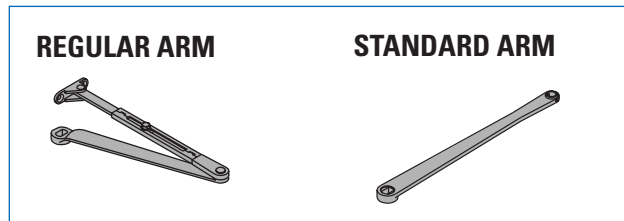

4. ADDITIONAL FORCES

Improperly hung doors, stiff latches, HVAC or environmental pressures, and other forces acting on the door require increasing the closer spring power to reliably close and latch a door which produces a corresponding increase in opening force.

INFORMATION SOURCES

LCN CLOSERS
121 W. RAILROAD AVE.
P.O. BOX 100
PRINCETON, IL, USA 61356-0100

PHONE 800-526-2400
FAX 800-248-1460
www.lcnclosers.com

U.S. DEPARTMENT OF JUSTICE

The Office of the Americans with Disabilities Act, Civil Rights Div.,
P.O. Box 66118, Washington, D.C. 20035-6118
(202) 514-0301

THE U.S. ARCHITECTURAL AND TRANSPORTATION BARRIERS COMPLIANCE BOARD

1111 18th Street N.W., Suite 501, Washington, D.C. 20036
(800) 872-2253

AMERICAN NATIONAL STANDARDS INSTITUTE

11 West 42nd Street, New York, N.Y. 10036
(212) 642-4900

- ANSI A117.1 Providing Accessibility and Usability for Physically Handicapped People
- ANSI A156.4 for Door Controls - Closers
- ANSI A156.19 Power Assist and Low Energy Power Operated Doors

ELECTROHYDRAULIC & PNEUMATIC FASTENERS

Standard WOOD and MACHINE SCREW (WMS) pack contains phillips head wood and machine screws to install the closer. Through Bolts (TB) and/or TORX® machine screws are available for all closers, except the 2610 series. LCN through bolts can be installed on 1 3/4" thick doors with either the 1/4-20 machine screws or optional TORX security screws supplied with the closer. Optional sizes are available for 1 5/8" or 1 3/8" door thicknesses, but must be specified when ordering.

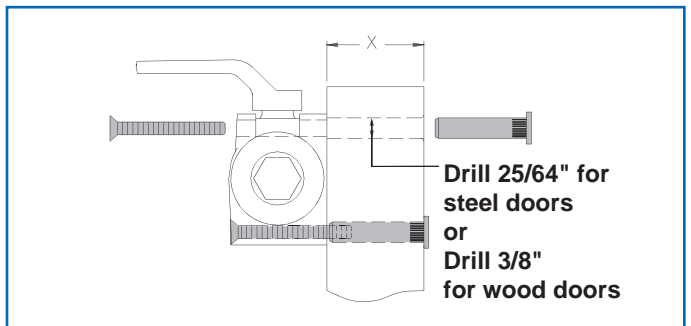

Note 1: Phillips head, metric machine screws are available, please specify.

ELECTROMECHANICAL FASTENERS

Typically installed 1/4 - 20 machine screw for aluminum/steel frames. Wood screws included for wood door mounting. Consult factory for additional information.

LOW ENERGY OPERATORS

The basic design concept for all LCN power operator systems is door control of both the opening and closing motion of the door. Our designs allow the system to be easily retrofitted into existing doors and frames as well as new construction.

A basic LCN electrohydraulic/pneumatic system consists of a power operator based on a heavy duty LCN 4040 Series door closer and peripheral actuators.

Our electromechanical power operators utilize a motor gearbox and a control box to perform the opening and closing function.

LCN offers a choice of either electrohydraulic, electromechanical or pneumatic low energy power operators.

APPLICATIONS

- ▶ Electrohydraulic and pneumatic systems are used primarily for manual opening with available push button automatic opening.
- ▶ Electromechanical systems are used primarily for automatic openings.
- ▶ For dedicated handicap access.
- ▶ Stand alone or integrated into larger multi-door systems.
- ▶ Surface and concealed mountings.
- ▶ Installation accessories available for unusual conditions.
- ▶ **Caution! For exterior doors exceeding 3'0" wide by 7'0" tall, interior doors exceeding 4'0" wide by 8'0" tall, or any door exceeding 225 pounds, consult factory before specifying or installing LCN electrohydraulic or pneumatic power operators.**
- ▶ **Caution! For exterior doors exceeding 4'0" wide by 7'0" tall, interior doors exceeding 4'0" wide by 8'0" tall, or any door exceeding 200 pounds, consult factory before specifying or installing LCN Electromechanical power operators.**

A156.19 SYSTEM DESIGN PARAMETERS

- ▶ Cycle test standard of 300,000 full load operating cycles.
- ▶ Power opening plus full door control.
- ▶ Open to backcheck no faster than 3 seconds.
- ▶ Opening time to fully open is no faster than 4 seconds.
- ▶ Remain fully open for at least 5 seconds.
- ▶ Closing time from 90° to 10° is no faster than 3 seconds.
- ▶ Less than 15 lbf to stop doors motion.
- ▶ Kinetic energy must not exceed 1.25 lbf-ft.
- ▶ In event of failure, less than 15 lbf to release latch, less than 30 lbf to put door in motion, less than 15 lbf to fully open door system.

COMMON SYSTEM FEATURES

- ▶ Power opening plus full door control.
- ▶ No guide rails or safety devices required due to low energy design.
- ▶ Adjustable opening force.
- ▶ Adjustable closing power.
- ▶ Operators meet ADA reduced manual opening force requirements, this includes 4630 and 4810.
- ▶ Electrohydraulic and pneumatic systems feature adjustable backcheck that slows opening swing at about 70°.
- ▶ Electromechanical systems feature electronic backcheck that slows opening swing at about 70°.
- ▶ Systems allow for separate adjustment of general closing and latch speed.
- ▶ Electrohydraulic and pneumatic systems are available in seven standard or a wide selection of optional custom powder coat finishes to blend with door and frame.
- ▶ Electromechanical systems are available in two standard anodized finishes or optional custom anodized and custom paint finishes to blend with door and frame.
- ▶ UL & NEC compliant.
- ▶ Compatible with most security and safety systems.
- ▶ Capable of full integration with high security keypads and card readers.
- ▶ Wiring allows for sequential operation for vestibule applications. Electromechanical systems require additional components.
- ▶ Modular design simplifies installation and maintenance.

WARRANTY

- ▶ 2 year limited warranty. See General Section for complete details.

MAINTENANCE

- ▶ Operators mounted according to the LCN installation instructions require no periodic maintenance or adjustments.
- ▶ Monthly, quarterly and annual visual inspections are recommended.

POWER OPERATORS

FEATURES

HIGH ENERGY OPERATORS

The basic design concept for all LCN power operator systems is door control of both the opening and closing motion of the door. Our designs allow the system to be easily retrofitted into existing doors and frames as well as new construction.

Our Electromechanical power operators utilize a motor gearbox and a control box to perform the opening and closing function.

LCN offers a choice of electromechanical high energy power operators.

APPLICATIONS

- ▶ Electromechanical high energy systems are used primarily for automatic openings.
- ▶ Power operated pedestrian doors.
- ▶ Well suited for high traffic, high volume areas.
- ▶ Surface and concealed mountings.
- ▶ Installations accessories available for unusual conditions.
- ▶ **Caution! For exterior doors exceeding 4'0" wide by 7'0" tall, interior doors exceeding 4'0" wide by 8'0" tall, or any door exceeding 200 lbs. consult factory before specifying or installing LCN high energy Electromechanical power operators.**
- ▶ **Caution! High energy electromechanical power operators require the use of guide rails and safety devices to be in compliance with ANSI 156.10.**

A156.10 SYSTEM DESIGN PARAMETERS

- ▶ Cycle test standard of 300,000 full load operating cycles
- ▶ Manual opening force shall not exceed 30lbs
- ▶ Latch position shall occur for swinging doors at no less than 10° from closed position.
- ▶ Opening time of a swinging door from fully closed to backcheck no faster than 1.5 seconds.
- ▶ Center pivoted doors shall have provisions for finger guard protection if the door clearance at hinge side is greater than 1/4" (6 mm) inch but less than 3/4" (19mm) with door in any position. (Consult door manufacturer)
- ▶ Requires the use of guide rails and safety devices.

COMMON SYSTEM FEATURES

- ▶ Power opening, spring return.
- ▶ Microprocessor control unit for quiet efficiency.
- ▶ Adjustable opening, closing and backcheck speed.
- ▶ Power Boost closing provides an additional 25 lbs of latching force.
- ▶ Electromechanical high energy systems are available in two standard anodized finishes or optional custom anodized and custom paint finishes can be ordered to blend with door and frame.
- ▶ Quick connect wiring system with Molex type plugs.
- ▶ Self-contained power operators in a cast aluminum housing and a forged steel arm.



High Energy Operators must be ordered with guide rails & safety devices.

WARRANTY

- ▶ 2 year limited warranty. See General Section for complete details.

MAINTENANCE

- ▶ High energy power operators may require periodic maintenance and/or adjustments.
- ▶ Daily visual inspections are recommended to ensure proper operation of all activation and safety devices.