

SWING UP GRAB BAR

- 1-1/4" O.D.
- Swings Up When Not In Use
- Heavy Duty Stainless Steel

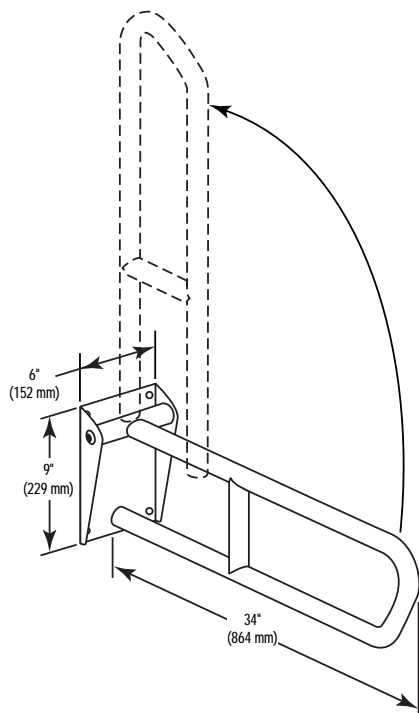
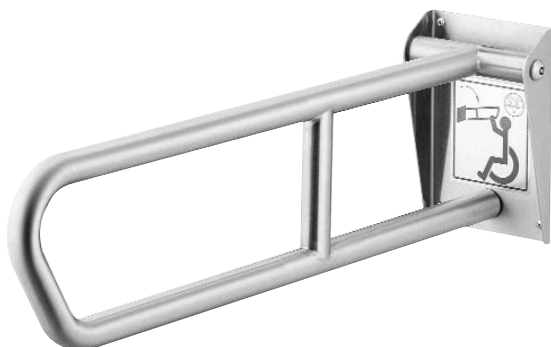

CONSTRUCTION:

- **TUBING** of type 304 (18-8), 1-1/4" O.D. 18 gauge stainless steel, seamless construction with exposed surfaces in architectural satin finish. All welds ground and polished to blend. Mandrel bending process maintains uniform bar diameter.
- **WALL PLATE** fabricated of 14 gauge type 304 (18-8) stainless steel with exposed surfaces in architectural satin finish. Concealed mechanism holds bar up and out of the way.

STRENGTH:

Swing up grab bar is only as strong as the wall and anchors to which it is attached. Grab bar must be securely fastened to wall to withstand the load it is intended to support.

OPERATION:

Grab bar is manually lowered to horizontal support position and raised for departure. Bar is designed to prevent it from accidentally falling into position. Bar operates with less than 5 pounds of force.

INSTALLATION:

Secure to wall where adequate in-wall backing exists. Use bar as template to locate mounting holes. Drill holes and set anchors as appropriate. Mount grab bar and secure mounting screws. (For Bradley grab bar mounting kits, refer to Mounting Kits page at back of Grab Bar section.) Mark point of contact with wall when bar is in raised position. Secure bumper to wall with screw at this point.

OPTIONAL FEATURES:

Feature	Suffix
<input type="checkbox"/> Safety-grip finish	-2

GUIDE SPECIFICATION:

Swing up grab bar shall be fabricated of type 304 (18-8) stainless steel with exposed surfaces in architectural satin finish. Install with Bradley Mounting Kits as indicated.

Swing Up Grab Bar shall be Bradley Model 8370-102.

Document No. 8842

This information is subject to change without formal notice.
© 2003 Bradley Corporation
12-4-2003

Bradley 

P.O. Box 309, Menomonee Falls, WI 53052-0309
Phone 1-800-BRADLEY FAX 262-253-4161
Web Site: <http://www.bradleycorp.com>
Technical Information Fax Service: 1-800-BRADFAX