

STAINLESS STEEL MIRROR

- Unbreakable
- Stainless Steel
- No. 8 Architectural Bright Finish

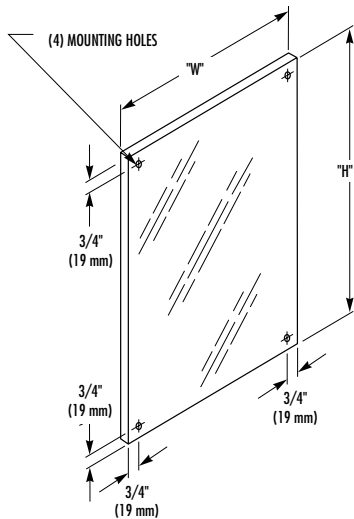

CONSTRUCTION:

- **MIRROR** fabricated of type 304 (18-8), 20 gauge stainless steel, polished to No. 8 architectural bright finish. Stretcher leveled for uniformity. Very bright – excellent reflectivity, very slight polish grain. 1/4" return conceals backing.
- **BACKING** of tempered Masonite bonded to mirror with adhesive.
NOTE: Stainless steel mirrors will differ in optic quality from glass mirrors.

INSTALLATION:

Secure to wall with tamper-resistant mounting screws (included) at holes provided.
NOTE: Provide in-wall backing at mounting screw locations.

GUIDE SPECIFICATION:

Mirror shall be fabricated of type 304 (18-8), 20 gauge stainless steel with No. 8 architectural finish. Unit shall have 1/4" return to conceal 1/4" tempered Masonite backing bonded to mirror with adhesive.

Stainless Steel Mirror shall be Bradley Model 748-_____ "W x _____ "H (specify width and height).

APPROVED SUBMITTALS ARE REQUIRED FOR ALL MIRRORS LARGER THAN 24" X 24".

In larger sizes, these units are subject to distortion and/or "oil canning" for which Bradley Corporation cannot accept responsibility.

Document No. 8740

This information is subject to change without formal notice.
© 2004 Bradley Corporation
12-21-2004

Bradley

P.O. Box 309, Menomonee Falls, WI 53052-0309
Phone 1-800-BRADLEY FAX 262-253-4161
Web Site: <http://www.bradleycorp.com>