

TOWEL DISPENSER

- Surface Mounted
- Roll Paper Towels
- Lever Operated

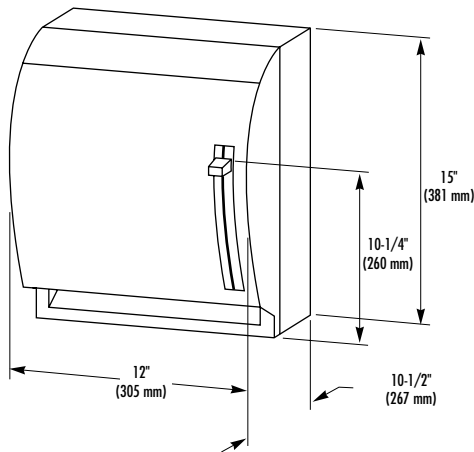
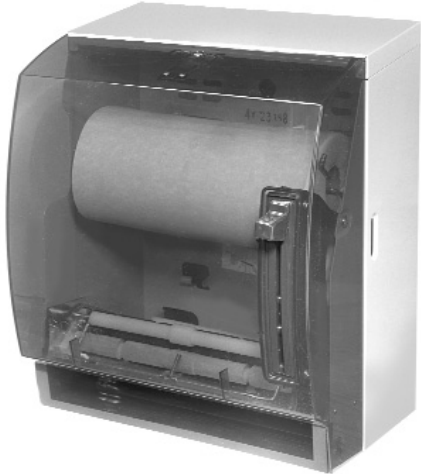

CONSTRUCTION:

- UNIT body fabricated of 20 gauge steel. Top fabricated of 18 gauge steel. Body and top finished with grey high-gloss baked enamel. Door fabricated of smoked transparent high-impact plastic.

CAPACITY:

One 8" or 9" wide paper towel roll and one partial (stub) roll.

OPERATION:

Lever operated dispensing mechanism will provide an adjustable means to dispense a nominal 5 inches, 4 inches or 2-1/2 inches of toweling per lever stroke. Toweling will only be dispensed with the downward stroke of the lever.

INSTALLATION:

Secure to wall using convenient mounting slots and appropriate mounting devices.

GUIDE SPECIFICATION:

Cabinet sides and back shall be fabricated from 20 gauge steel, with 18 gauge steel on top, pre-treated and finished with a baked enamel. The door will be transparent and the throat an opaque high impact plastic. The front cover shall be fabricated of smoked transparent high-impact plastic.

Cabinets shall have a lever-operated dispensing mechanism. The operating lever is to be located on the front of the dispenser.

Cabinet will be provided with a key activated spring lock, which can easily be converted to push-button operation. Each cabinet will be provided with a key and push-button.

Cabinets shall include a transfer system which will automatically start feeding the paper web of the top roll when the lower roll is nearly depleted.

The drive mechanism, transfer system, roll holders and door shall be field replaceable.

Overall dimensions: 12"W x 15"H x 10-1/2"D.

Surface Mounted Roll Paper Towel Dispenser shall be Bradley Model 2491.

Document No. 8205

This information is subject to change without formal notice.
© 2004 Bradley Corporation
12-21-2004

Bradley 

P.O. Box 309, Menomonee Falls, WI 53052-0309
Phone 1-800-BRADLEY FAX 262-253-4161
Web Site: <http://www.bradleycorp.com>