

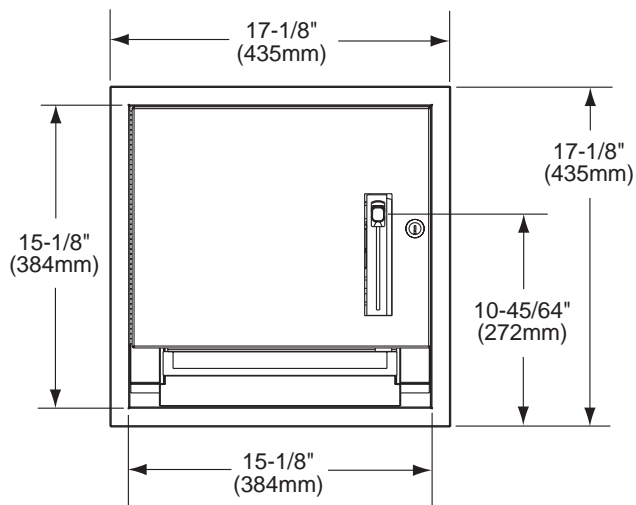

TOWEL DISPENSER

- Roll Paper Towel
- Model 2484-000000 – Recess Mounted  (recesses 10-1/4", projects 1-3/8")
- Model 2484-100000 – Semi-recessed Mounted (recesses 3-1/2", projects 7")

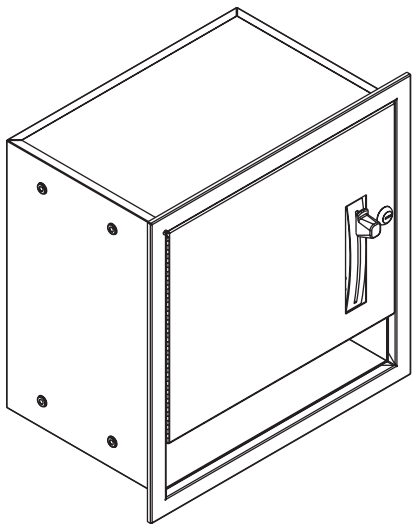

MODEL 2484-000000

 When installed as specified below, unit meets Barrier-Free requirements

CONSTRUCTION:

- **CABINET** fabricated of type 304 (18-8), 22 gauge stainless steel with exposed surfaces in satin finish. All welded construction.
- **DOOR** fabricated of type 304 (18-8), 18 gauge stainless steel with exposed surfaces in satin finish. Door secured with full length stainless steel piano hinge and tumbler lock keyed like other Bradley accessory items.
- **TOWEL DISPENSER** Furnished (manufactured by others).

CAPACITY:

One standard core 8" or 9"W x 800'L roll paper towel roll.

OPERATION:

Towel dispenser delivers preset length of towel (2-1/2", 4" or 5" per stroke) by depressing lever. Operates with less than 5 lbs. of force to meet ADA requirements.

INSTALLATION:

Recessed unit requires rough wall opening 15-1/2"W x 15-1/2"H x 10-1/2"D (Semi-recessed unit requires 3-1/2"D). Top of wall opening 77" max above finished floor. Barrier-free application; top of wall opening 44-1/2" from finished floor. Secure to framing with mounting screws (included) at holes provided. Shim at screw points as required.

GUIDE SPECIFICATION:

Recessed or semi-recessed towel dispenser shall be fabricated of type 304 (18-8), stainless steel with exposed surfaces in satin finish. Cabinet door shall have full length piano hinge and be secured with tumbler lock. Towel dispenser shall be activated with less than 5 lbs. of force and have the capacity to hold one standard core 8" or 9" W x 800' L paper towel roll.

Overall dimensions: 17-1/8"W x 17-1/8"H x 10-1/2"D.

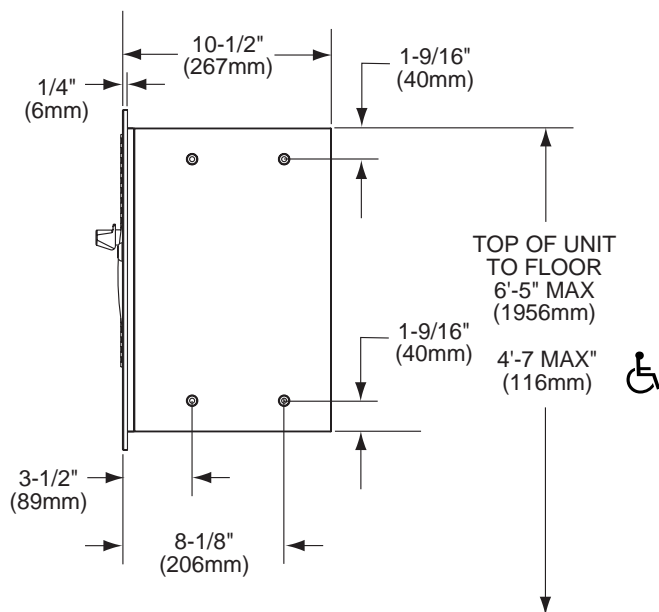

Document No. 8194