

HAND DRYER

- Recess Mounted
- Pushbutton Activated
- ADA Compliant
- Model 2896-28 – White unless another color specified

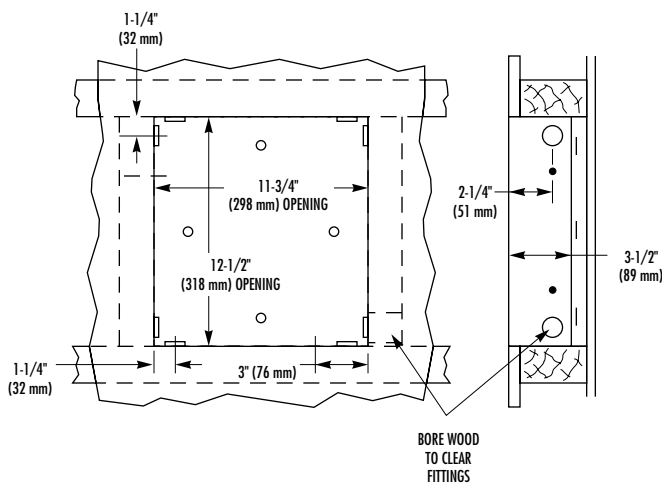
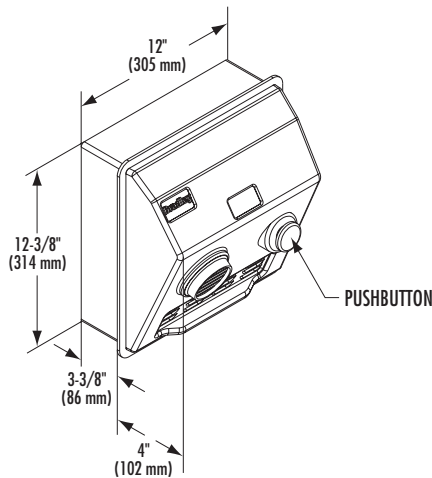
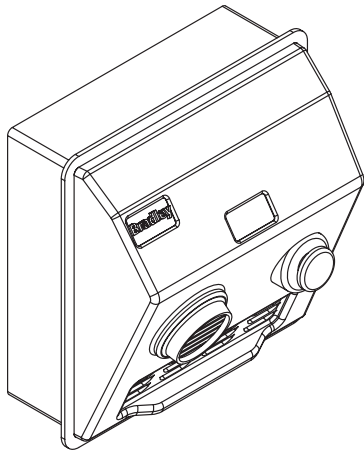

CONSTRUCTION:

- **COVER:** Fabricated of grey cast iron with porcelain enamel on all exterior surfaces.
- **WALL BOX:** Fabricated of 16 gauge enameled or plated steel.
- **NOZZLE:** Fabricated from rust and corrosion-free diecast zinc with chrome-plated finish. Fixed nozzle.
- **MOTOR:** is Universal type, 1/10 HP at 7500 RPM with resilient ring mounts and sealed, lubricated ball bearings. Protected by 2 amp fuse. 115 volt, 20 amp, 60 hz standard.
- **HEATING ELEMENT:** 2300 watt, nickel chromium wire wound on ceramic cruciforms with integral automatic resetting circuit breaker (2 amp fuse).

ELECTRONIC CONTROL:

Reflective infrared operating above inlet grill controlling electro-mechanical 25 Ampere rated relay. Switch off delay of 2 seconds max. and 80 second timeout function.

- **BLOWER:** Operates at 7500 RPM delivering 130 CFM at 140 deg. F. and average velocity of 7300 LFM.
- **BASE PLATE:** Fabricated of rust-free diecast aluminum; media polished to bright finish.
- **AIR INLET:** Positioned on lower face of cover. Inlet covered by expanded steel grillwork.
- **COVER LOCKING:** Cover secured by security allen head screws; special wrench provided.
- **ENTIRE UNIT:** U.L. listed and guaranteed against defects in material and/or workmanship for 10 years.

OPERATION:

Pushbutton.

OPTIONAL FEATURES:

Feature	Suffix
□ 208 Volt, 11 amp, 60 Hz	-29
□ 230 Volt, 10 amp, 50 Hz	-49
□ 230 Volt, 10 amp, 60 Hz	-53
□ 277 Volt, 8.5 amp, 60 Hz	-44

INSTALLATION:

Requires rough wall opening 11-3/4"W x 12-1/2"H. Minimum recessed depth required is 3-1/2" from finished wall surface. Secure wall box to rough-in framing with nails or screws; 2 attachment holes provided on sides, top and bottom of box. Attach conduit to wallbox at convenient knockout location; two knockouts are located 1-1/4" from each corner. Fasten base plate to wallbox through four holes in back of base with four screws provided. Connect electrical service to terminal block per base mounted wiring diagram. Attach cover to base before energizing dryer at breaker panel.

GUIDE SPECIFICATION:

Recess mounted hand dryer shall be fabricated from porcelain enameled grey cast iron fitted with fixed nozzle and pushbutton control. Universal type motor with resilient mounts and sealed, lubricated ball bearings; fuse protected, automatic reset circuit breaker protecting heating element. Wiring is single-phase. Dryer shall deliver 130 CFM of air at 140 degrees F and 7300 LFM velocity during user controlled drying cycle. Entire unit U.L. listed and guaranteed against defects in material and/or workmanship.

Overall dimensions shall be 12-1/2"W x 13-7/8"H x 4"D (Including nozzle tip).

Recess Mounted Hand Dryer shall be Bradley Model _____ (insert model number).

Document No. 8262

This information is subject to change without formal notice.
© 2003 Bradley Corporation
5-3-2004



P.O. Box 309, Menomonee Falls, WI 53052-0309
Phone 1-800-BRADLEY FAX 262-253-4161
Web Site: <http://www.bradleycorp.com>