

MODEL 2871/2881 2872/2882

HAND/HAIR DRYER

- Recess mounted
- Model 2871 – Hand Dryer-White
- Model 2881 – Hand Dryer-Color
(Specify color _____)
- Model 2872 – Hair Dryer-White
- Model 2882 – Hair Dryer-Color
(Specify color _____)

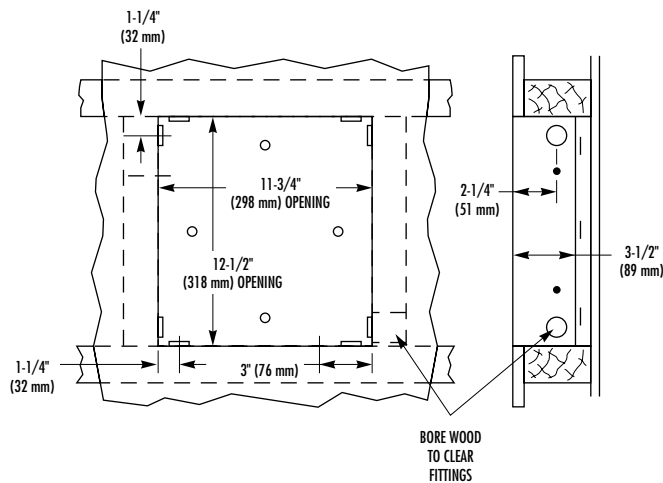

CONSTRUCTION:

- **COVER:** Fabricated of grey cast iron with porcelain enamel on all exterior surfaces.
- **WALLBOX:** 16 gauge enameled or plated steel.
- **NOZZLE AND PUSHBUTTON:** Fabricated of rust and corrosion-free diecast zinc with chrome-plated finish. Rotating nozzle. Model 2871/2881 nozzle-directs air straight down; Model 2872/2882 nozzle directs air out from vertical 20 degrees.
- **MOTOR:** is Universal type, 1/10 HP at 7500 RPM with resilient ring mounts and sealed, lubricated ball bearings. Protected by 2 amp fuse. 115 volt, 20 amp, 60 hz standard.
- **HEATING ELEMENT:** 2300 watt nickel chromium wire wound on ceramic cruciforms with integral automatic resetting circuit breaker.
- **SWITCH TIMER:** 25 ampere rated switch, 30 second timer Model 2871/2881; 80 second timer Model 2872/2882.
- **BLOWER:** Operates at 7500 RPM delivering 130 CFM at 140 deg. F. and average velocity of 7300 LFM.
- **BASE PLATE:** Fabricated of rust-free diecast aluminum; polished integral dress flange.
- **AIR INLET:** Lower face of cover, Model 2871/2881; upper face of cover, Model 2872/2882. Inlet covered by expanded steel grillwork.
- **COVER LOCKING:** Secured by two 1/4" diameter socket head safety screws; special wrench provided.
- **ENTIRE UNIT:** U.L. listed and guaranteed against defects in material and/or workmanship for ten (10) years.

OPERATION:

Press pushbutton and release to activate dryer. Rotate nozzle to direct air flow on face.

INSTALLATION:

Requires rough wall opening 11-3/4"W x 12-1/2"H. Minimum recessed depth required is 3-1/2" from finished wall surface. Secure wall box to rough-in framing with nails or screws; 2 attachment holes provided on sides, top and bottom of box. Attach conduit to wallbox at convenient knockout location; two knockouts are located 1-1/4" from each corner. Fasten base plate to wallbox through four holes in back of base with four screws provided. Connect electrical service to terminal block per base mounted wiring diagram. Attach cover to base before energizing dryer at breaker panel.

OPTIONAL FEATURES:

Features	Suffix
<input type="checkbox"/> Fixed nozzle (Models 2871/2881 only)	-28
<input type="checkbox"/> 208 Volt, 11 amp, 60 Hz	-29
<input type="checkbox"/> 230 Volt, 10 amp, 60 Hz	-53
<input type="checkbox"/> 230 Volt, 10 amp, 50 Hz	-49
<input type="checkbox"/> 277 Volt, 8.5 amp, 60 Hz	-44

GUIDE SPECIFICATION:

Recessed mounted hand (hair) dryer cover shall be fabricated of porcelain enameled grey cast iron fitted with insulated pushbutton and rotating nozzle. Dress flange to be polished aluminum integral with dryer base. Universal type motor with resilient mounts and sealed, lubricated ball bearings; fuse protected. Wiring is single-phase. Automatic reset circuit breaker protecting heating element. Dryer shall deliver 130 CFM of air at 140 F and 7300 LFM average velocity for 30 seconds (80 seconds for hair). Entire unit U.L. listed and guaranteed against defects in material and/or workmanship for 10 years. Overall dimensions: 12-1/2"W x 13-7/8"H x 3-1/2"D (5-1/4" at nozzle tip).

Recessed Mounted Hand (Hair) Dryer shall be Bradley Model _____ (insert model number).

Document No. 8240

This information is subject to change without formal notice.
© 2003 Bradley Corporation
12-20-2004

Bradley

P.O. Box 309, Menomonee Falls, WI 53052-0309
Phone 1-800-BRADLEY FAX 262-253-4161
Web Site: <http://www.bradleycorp.com>