

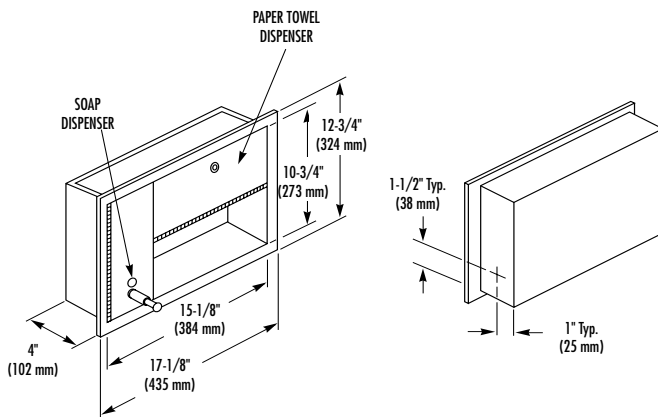

MULTI-PURPOSE UNIT

- ADA Compliant
- Towel/Soap Dispenser
- Model 1471 – Recessed
- Model 1471-11 – Surface Mounted (projects 4")



CONSTRUCTION:

- **FLANGE** fabricated of type 304 (18-8), 22 gauge stainless steel with exposed surfaces in architectural satin finish. One piece seamless construction, 1" wide with 1/4" return.
- **CABINET** fabricated of type 304 (18-8), 26 gauge stainless steel.
- **DOORS** fabricated of type 304 (18-8), 22 gauge stainless steel, with heavy duty full length piano hinge and tumbler lock keyed like other Bradley units.
- **SOAP DISPENSER CONTAINER** fabricated of polyethylene. Soap valve has chrome-plated brass housing with ABS plastic mechanism, and internal checks to prevent leakage. Requires less than 5 lbs. force to dispense soap.
- **TOWEL DISPENSER** fabricated of type 304 (18-8), 22 gauge stainless steel.

CAPACITY:

Soap Dispenser – 40 oz. liquid soap; Towel Dispenser – 250 multi-fold or 150 C-fold paper towels.

OPERATION:

Soap dispenser swings open for filling and cleaning. Sight gauge indicates refill time. Valve dispenses measured amount of liquid soap. Towel dispenser holds multi-fold or C-fold towels without use of special adaptor. Requires less than 5 lbs. force to dispense soap.

INSTALLATION:

Recessed unit requires rough wall opening 15-1/2"W x 11-1/4"H x 4"D. Secure to framing with mounting screws (included) at holes provided. Shim at screw points as required.

OPTIONAL FEATURES:

Feature	Suffix
<input type="checkbox"/> Lather soap valve in lieu of liquid	-13

GUIDE SPECIFICATION:

Recessed multi-purpose unit, consisting of towel dispenser and soap dispenser, shall be fabricated of type 304 (18-8), stainless steel with exposed surfaces in satin finish. Doors with full length piano hinge and tumbler lock. Unit dispenses 250 multi-fold or 150 C-fold paper towels and 40 oz. liquid soap. Requires less than 5 lbs. force to dispense soap.

Overall dimensions: 17-1/8"W x 12-3/4"H x 4"D.

Recessed Multi-Purpose Unit shall be Bradley Model 1471.

Document No. 8010