

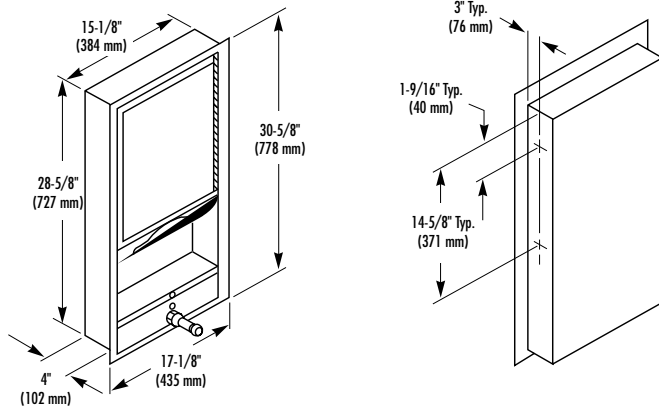

MULTI-PURPOSE UNIT

- ADA Compliant
- Model 130 – Recessed
- Model 130-10 – Semi recessed
(recesses 2"; projects 2")
- Model 130-11 – Surface Mounted
(projects 4")

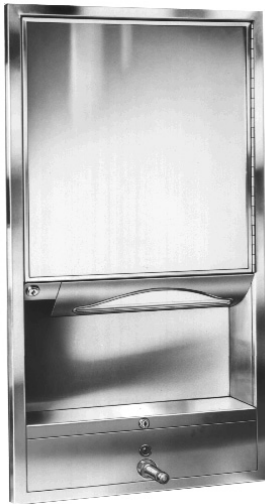

CONSTRUCTION:

- **FLANGE** fabricated of type 304 (18-8), 22 gauge stainless steel with exposed surfaces in architectural satin finish. One piece seamless construction, 1" wide with 1/4" return.
- **CABINET** fabricated of type 304 (18-8), 26 gauge stainless steel.
- **DOOR** fabricated of type 304 (18-8), 22 gauge stainless steel, with heavy duty full length piano hinge and tumbler lock.
- **MIRROR** of first quality 1/4" float glass triple-silvered, electro-copper plated with baked enamel backing, guaranteed for 15 years against silver spoilage. Protected by shock absorbing filler.
- **TOWEL DISPENSER** fabricated of type 304 (18-8), 22 gauge stainless steel. Rolled edge on dispenser opening.
- **EXTERIOR SHELF** fabricated of type 304 (18-8), 22 gauge stainless steel with an area of 60 sq. in.
- **SOAP DISPENSER** fabricated of type 304 (18-8), 22 gauge stainless steel with tumbler lock. Soap valve has chrome-plated brass housing with ABS plastic mechanism, and internal checks to prevent leakage. High impact polystyrene liner. Requires less than 5 lbs. force to dispense soap.
- **LOCKS** on door and soap dispenser keyed like other Bradley units.

CAPACITY:

Towel Dispenser – 800 multi-fold or 600 C-fold paper towels; Soap Dispenser – 100 oz. liquid soap.

OPERATION:

Towel dispenser holds multi-fold or C-fold towels with use of special adaptor. Soap dispenser slides open for filling and cleaning. Sight gauge indicates refill time. Valve dispenses measured amount of liquid soap. Requires less than 5 lbs. force to dispense soap.

INSTALLATION:

Recessed unit requires rough wall opening 15-5/8"W x 29-1/8"H x 4"D (Semi-recessed unit only 2" deep). Top of wall opening 6'-1" above finished floor. Secure to framing with mounting screws (included) at holes provided. Shim at screw points as required.

OPTIONAL FEATURES:

Feature	Suffix
<input type="checkbox"/> Lather soap valve in lieu of liquid	-13
<input type="checkbox"/> Two liquid soap valves	-14
<input type="checkbox"/> Interior shelves, small capacity towel cabinet	-16
<input type="checkbox"/> Single-folded towels (7-1/2" depth, 1,000 capacity)	-20
<input type="checkbox"/> Stainless steel door in lieu of mirror	-21
<input type="checkbox"/> Tempered glass in lieu of float glass	-22
<input type="checkbox"/> #8 Stainless steel mirror in lieu of glass	-23
<input type="checkbox"/> Adjustable tilt mirror	-25
<input type="checkbox"/> Fixed tilt mirror	-26
<input type="checkbox"/> Cup dispenser	-27

NOTE: An inherent characteristic of a manufacturing process is distortion which may vary from mirror to mirror.

GUIDE SPECIFICATION:

Recessed multi-purpose unit consisting of mirror, towel dispenser, cup dispenser, shelf and 100 oz. liquid soap dispenser, shall be fabricated of type 304 (18-8), stainless steel with exposed surfaces in satin finish. Mirrored door with full length piano hinge and tumbler lock. Towel dispenser capacity 800 multi-fold or 600 C-fold towels. Requires less than 5 lbs. force to dispense soap.

Overall dimensions: 17-1/8"W x 30-5/8"H x 4"D.

Recessed Multi-Purpose Unit shall be Bradley Model 130.